

# Skonaren VEGA

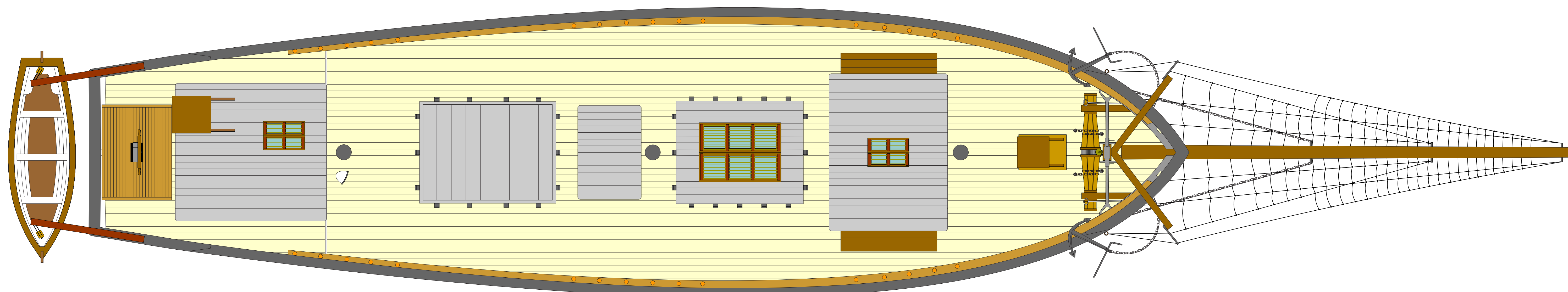

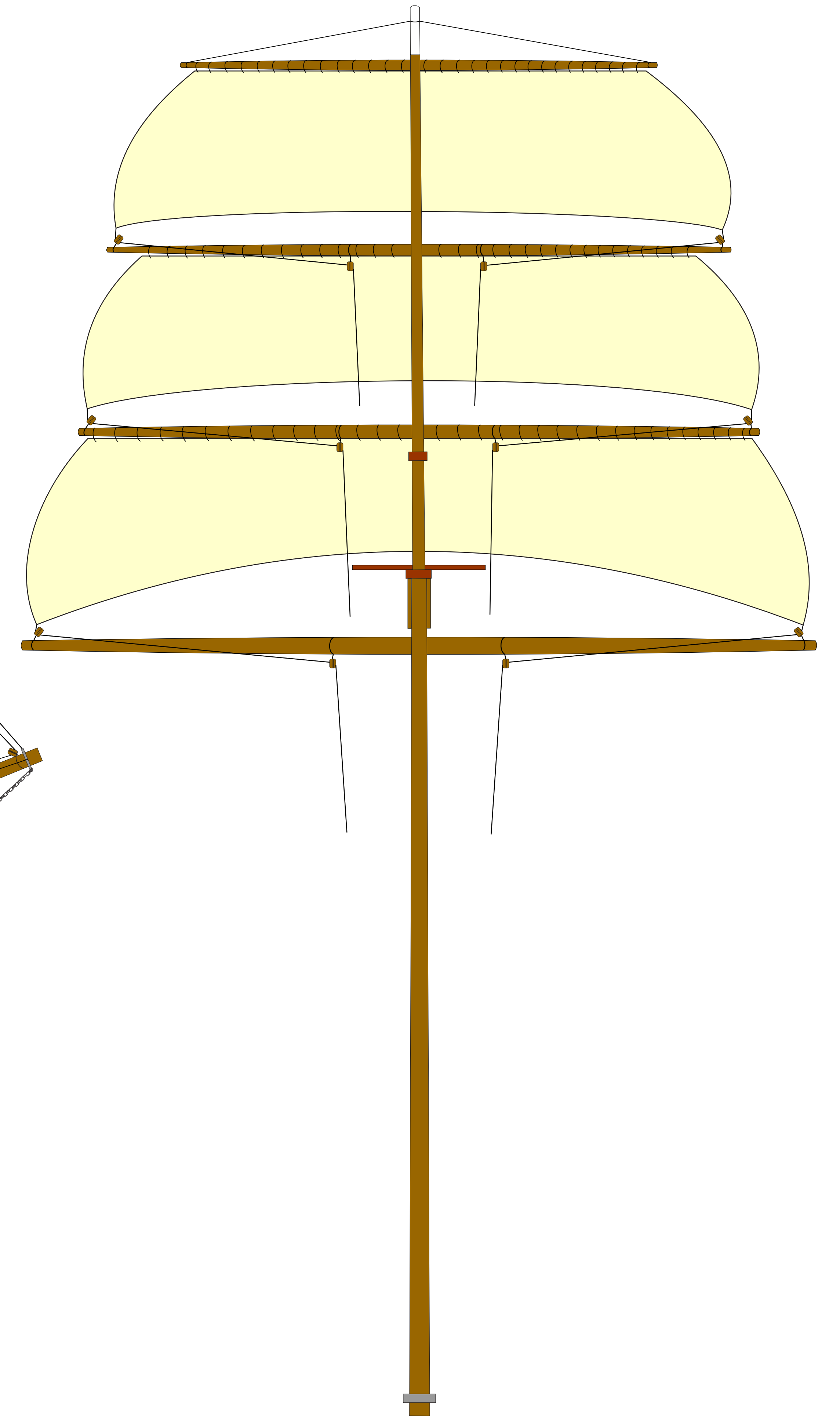

8

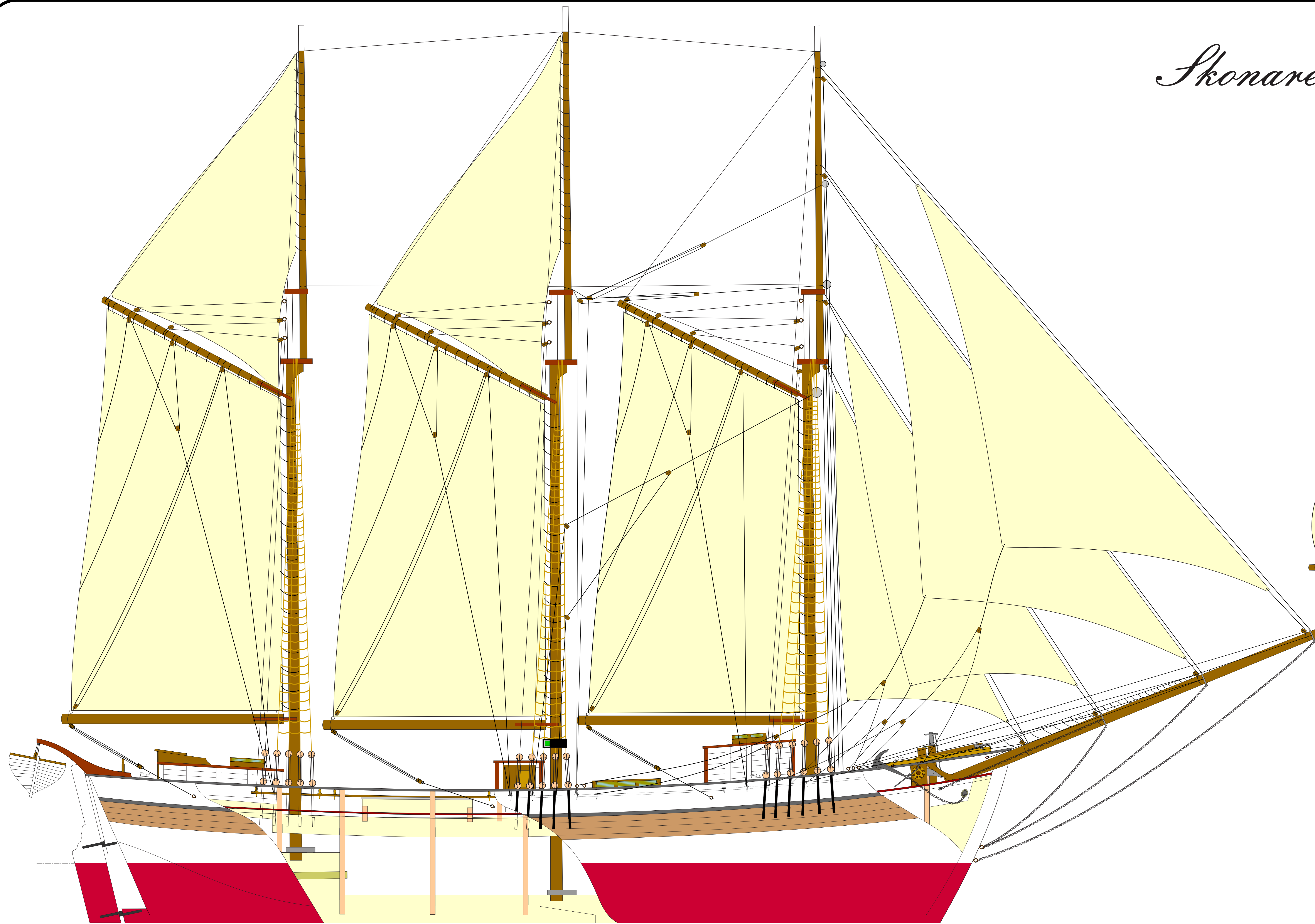
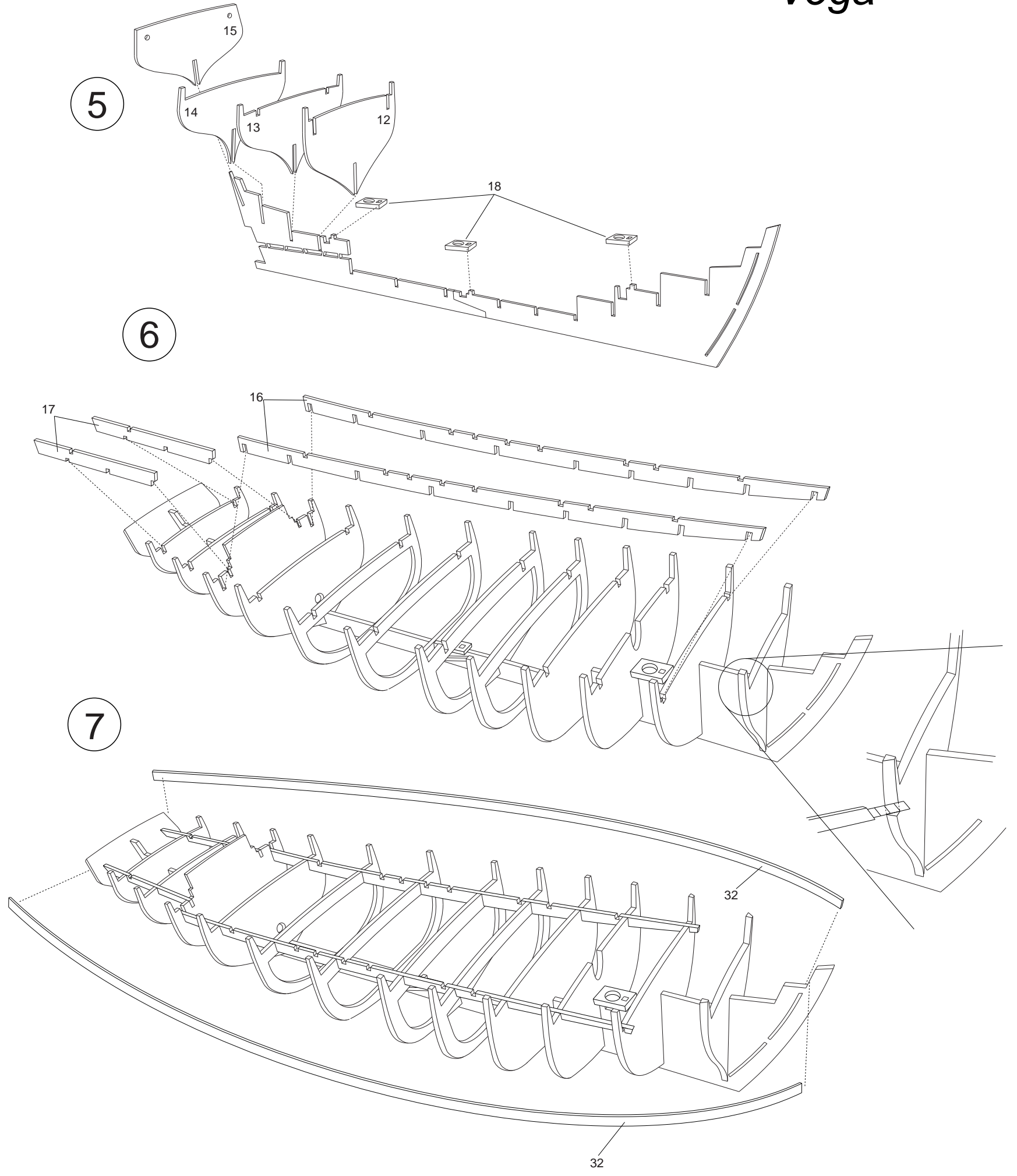
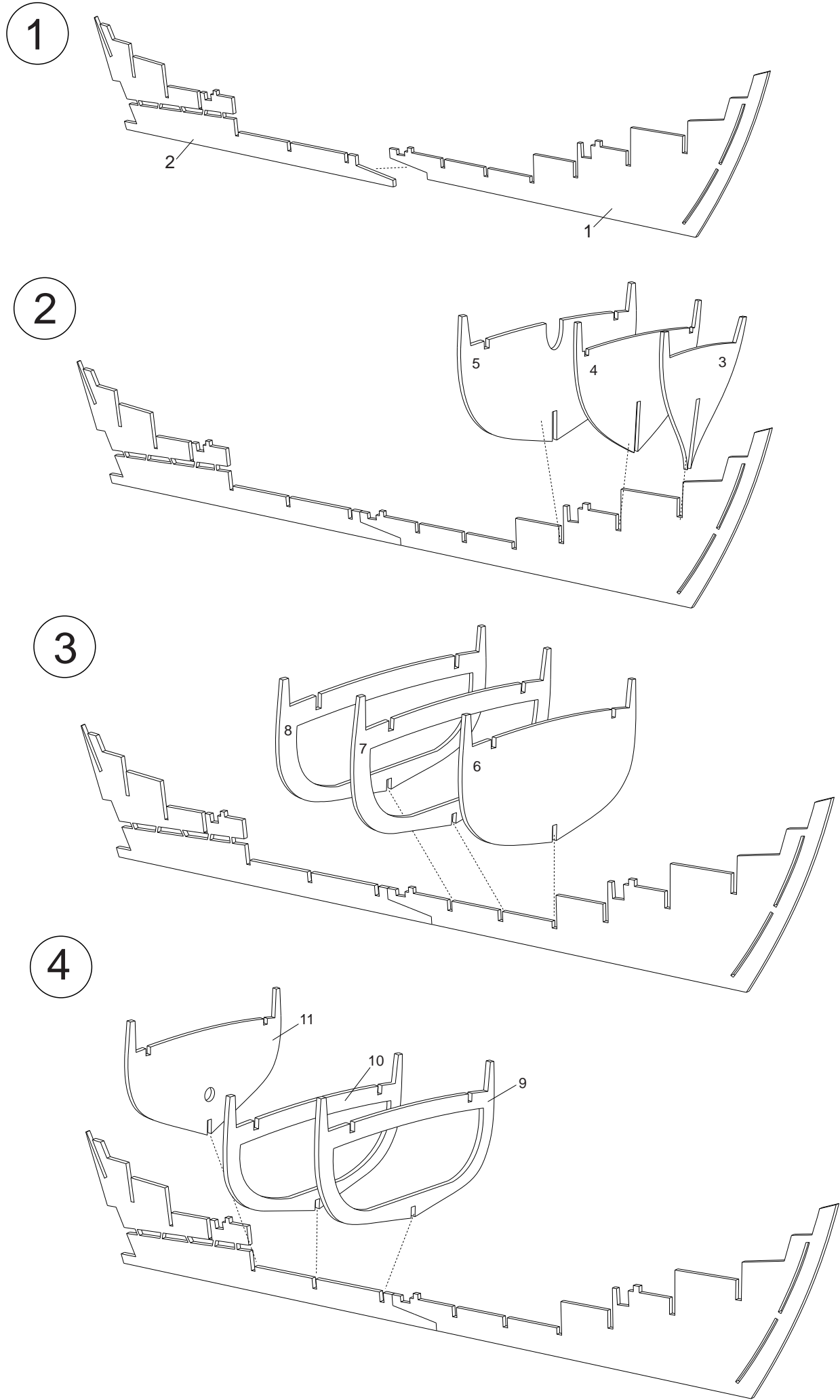
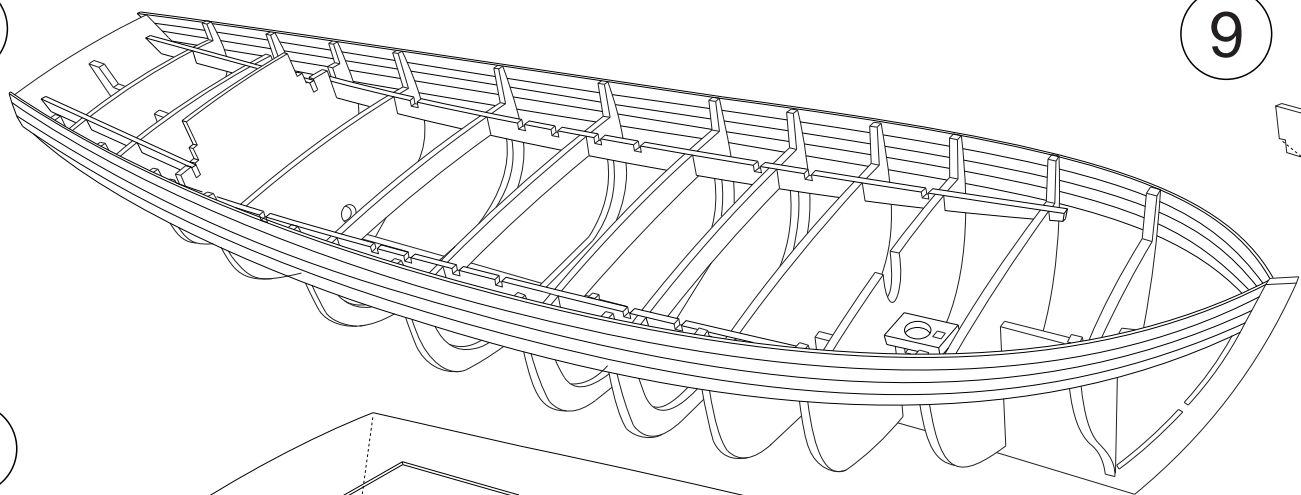

9

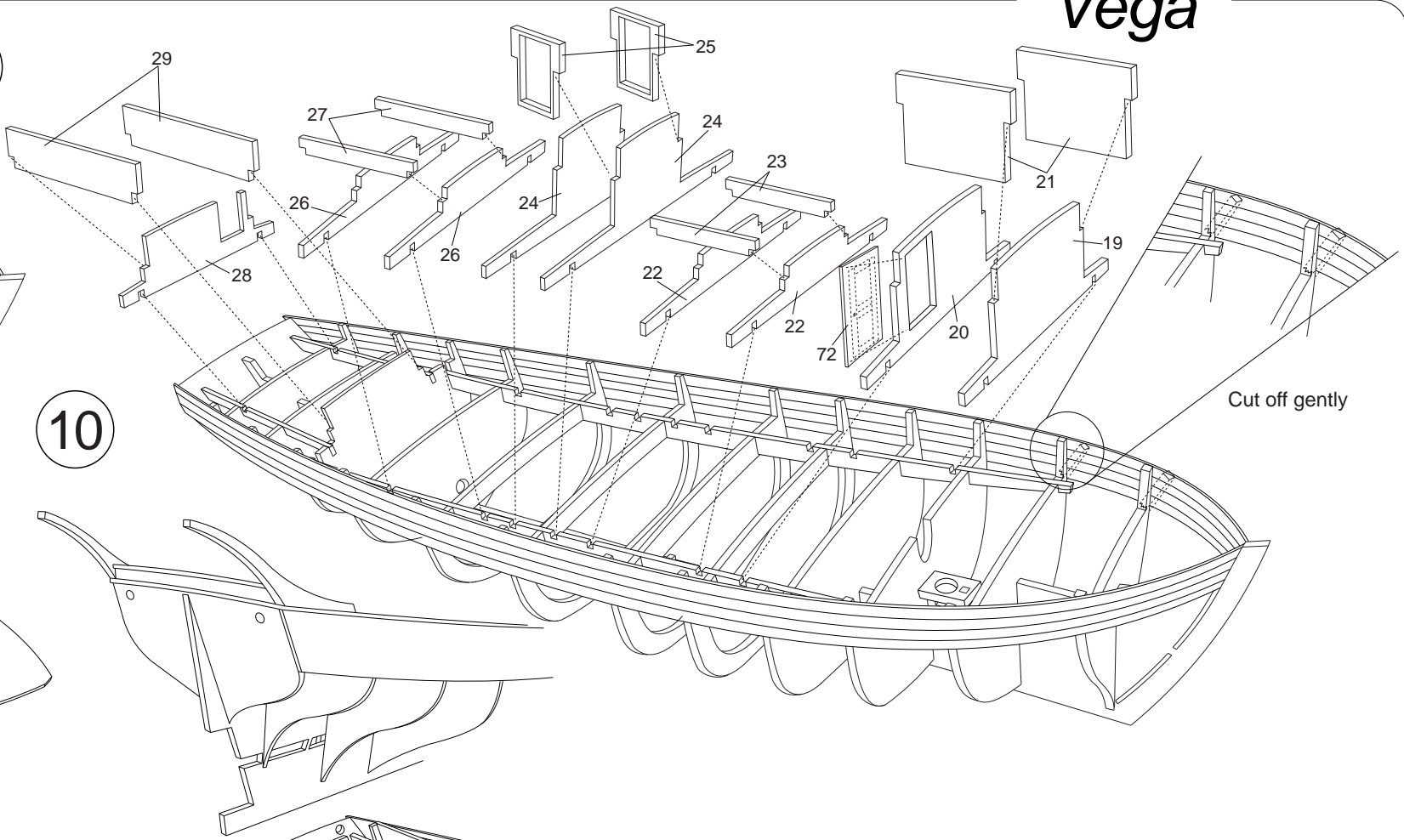

11

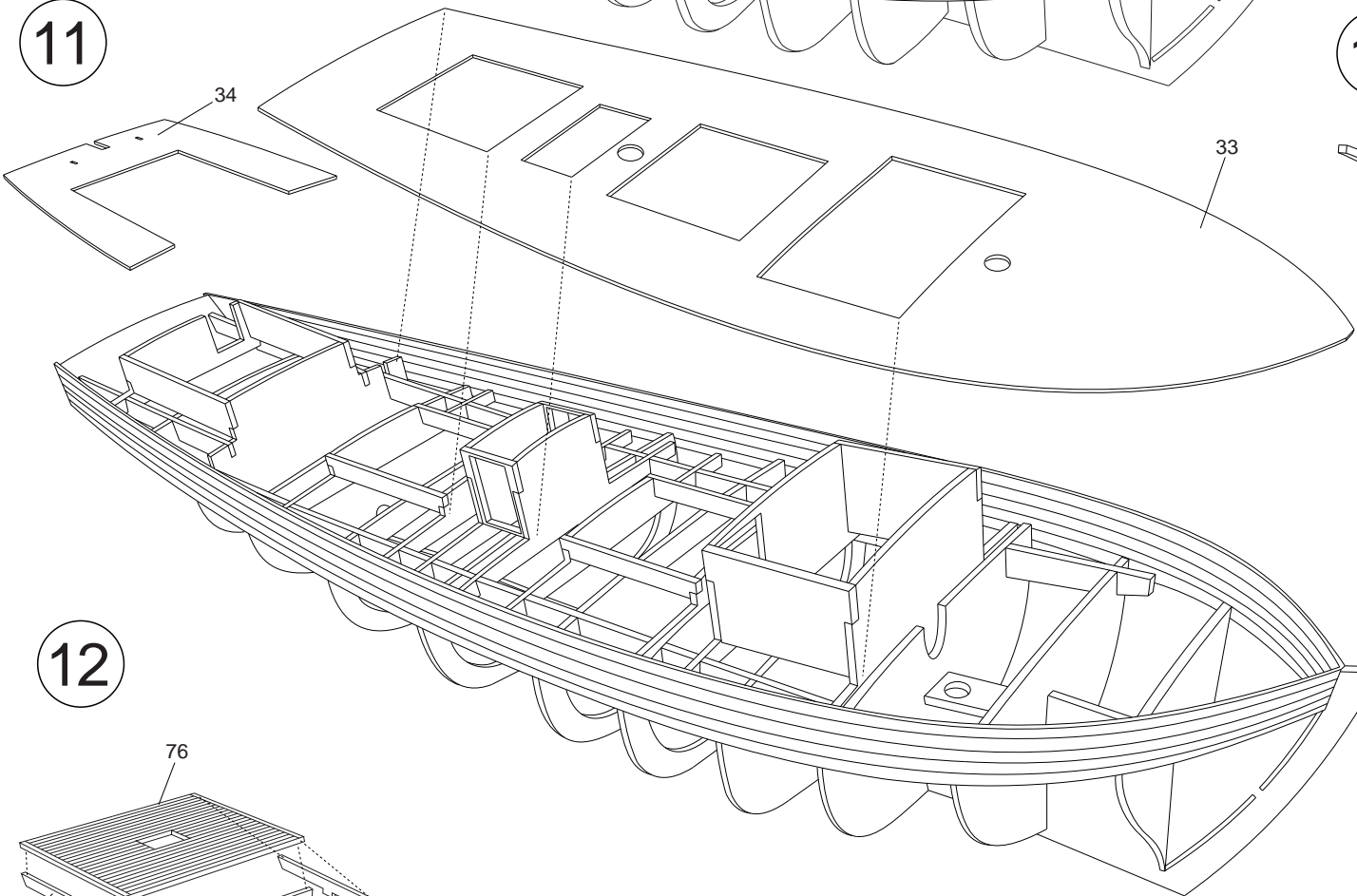

10

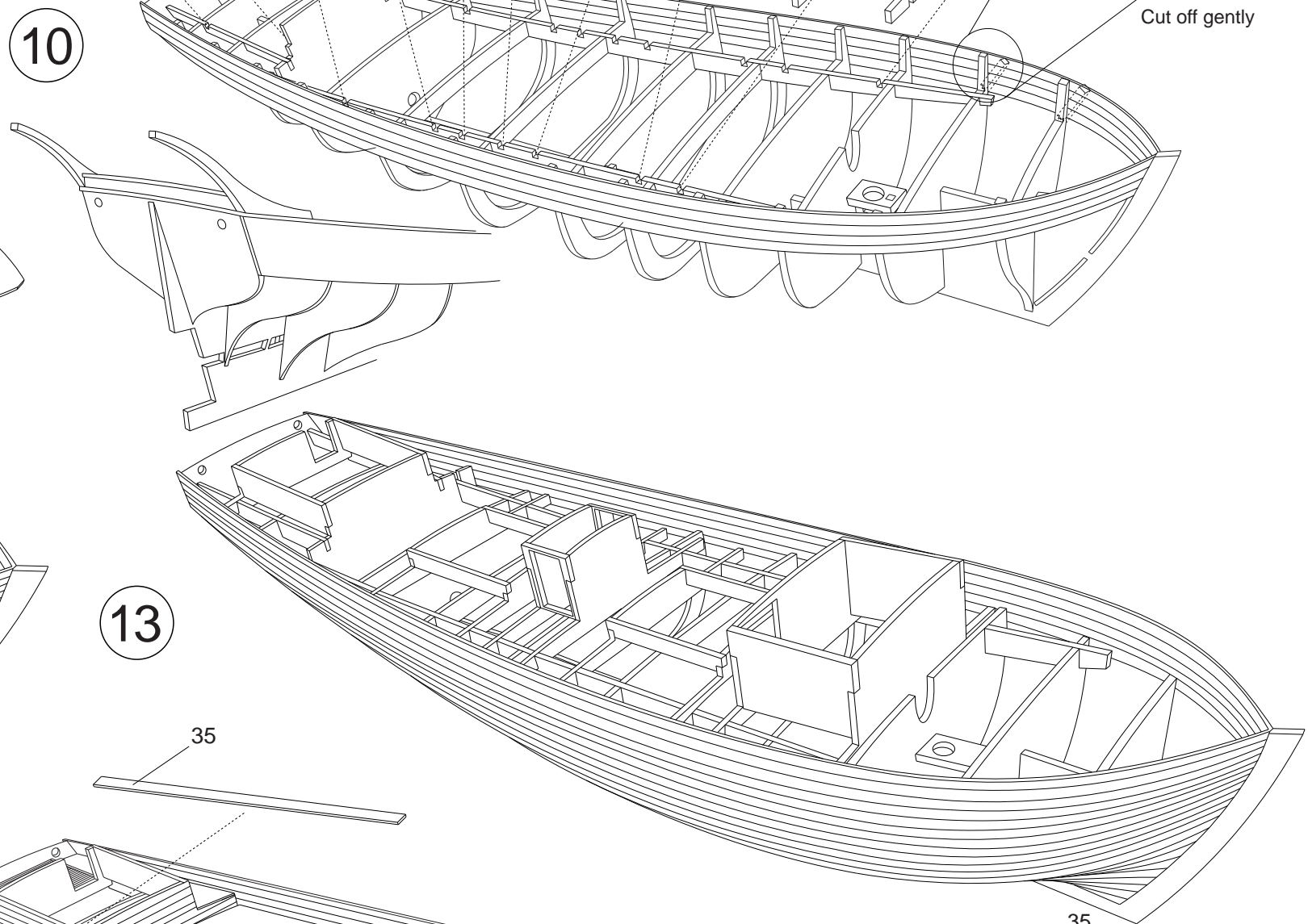

12

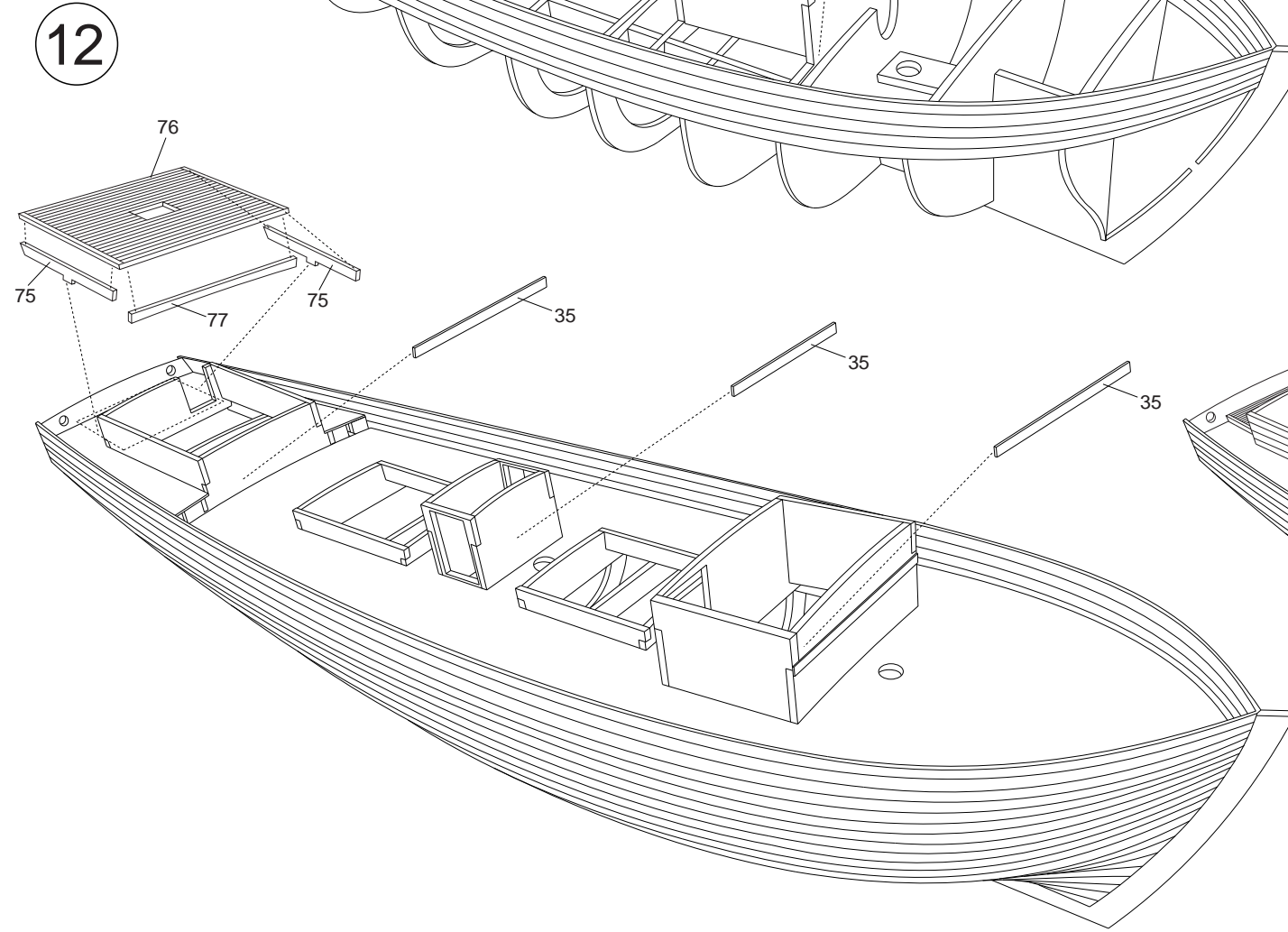

13

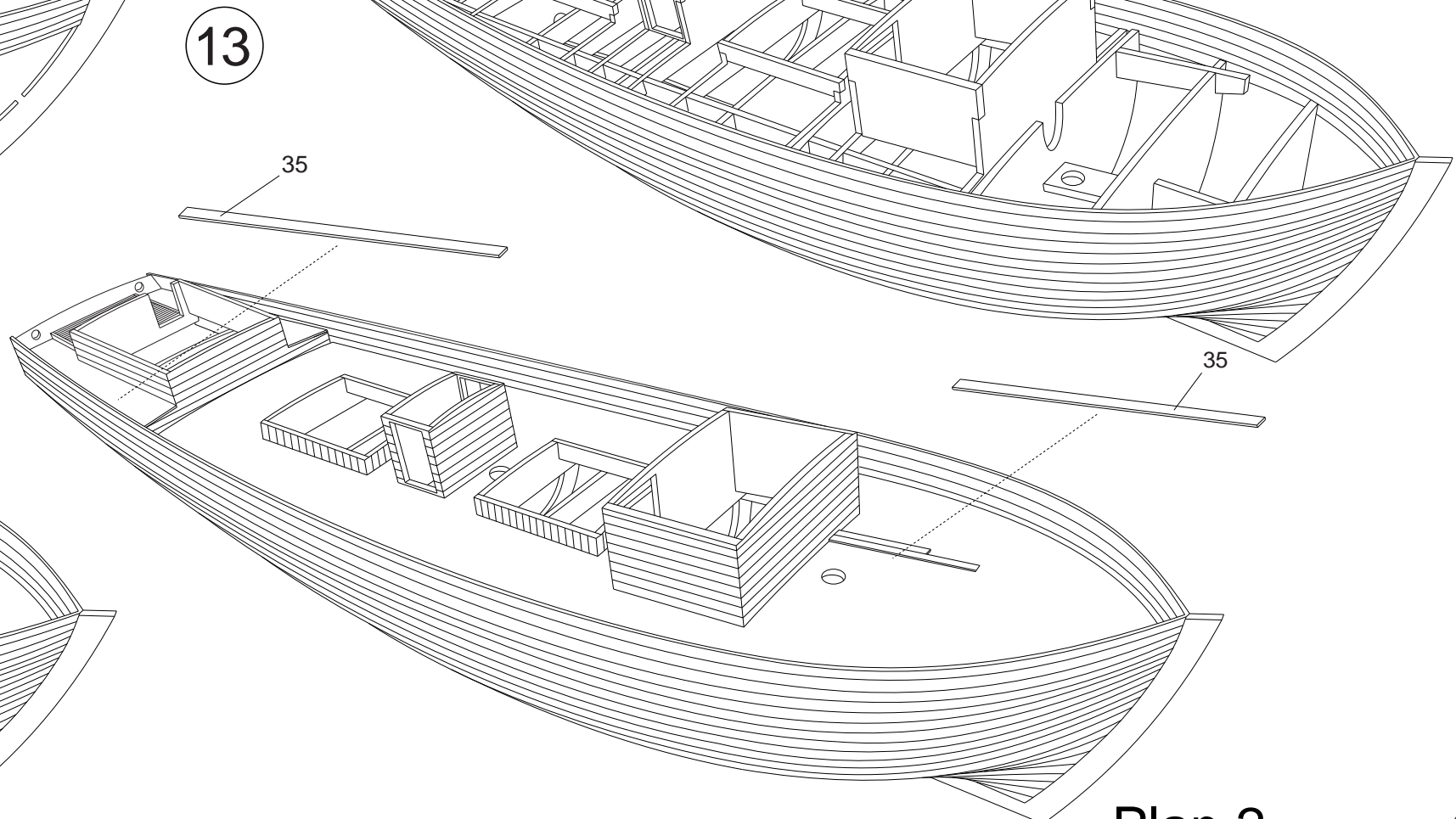

14

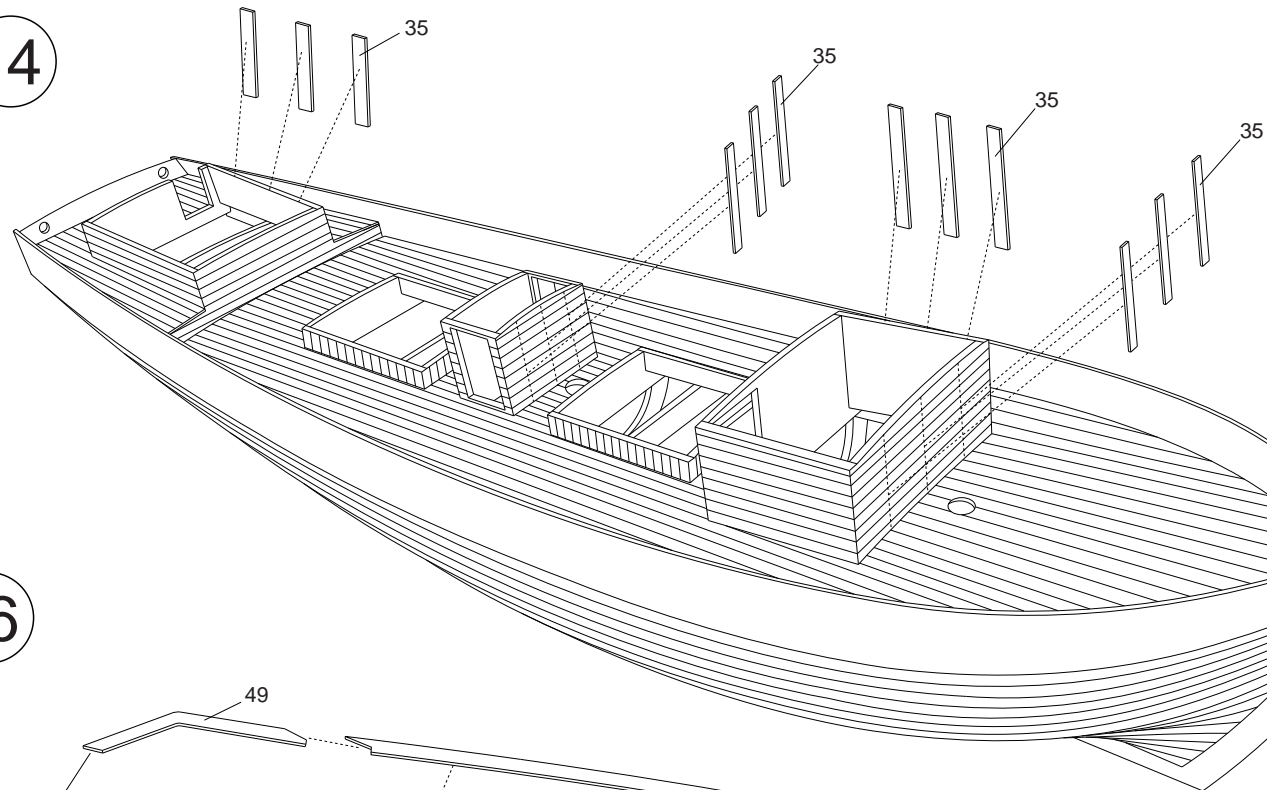

15

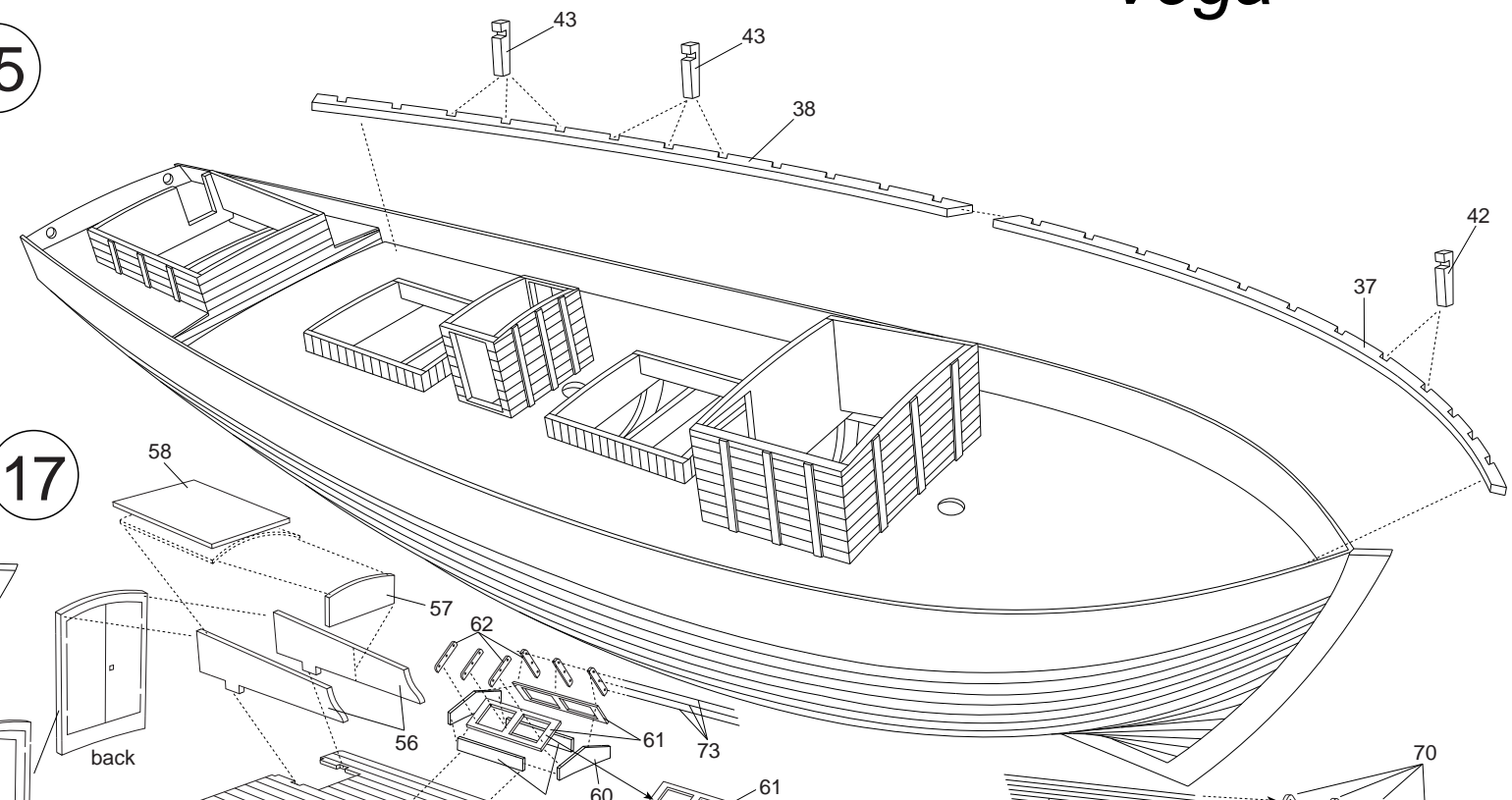

16

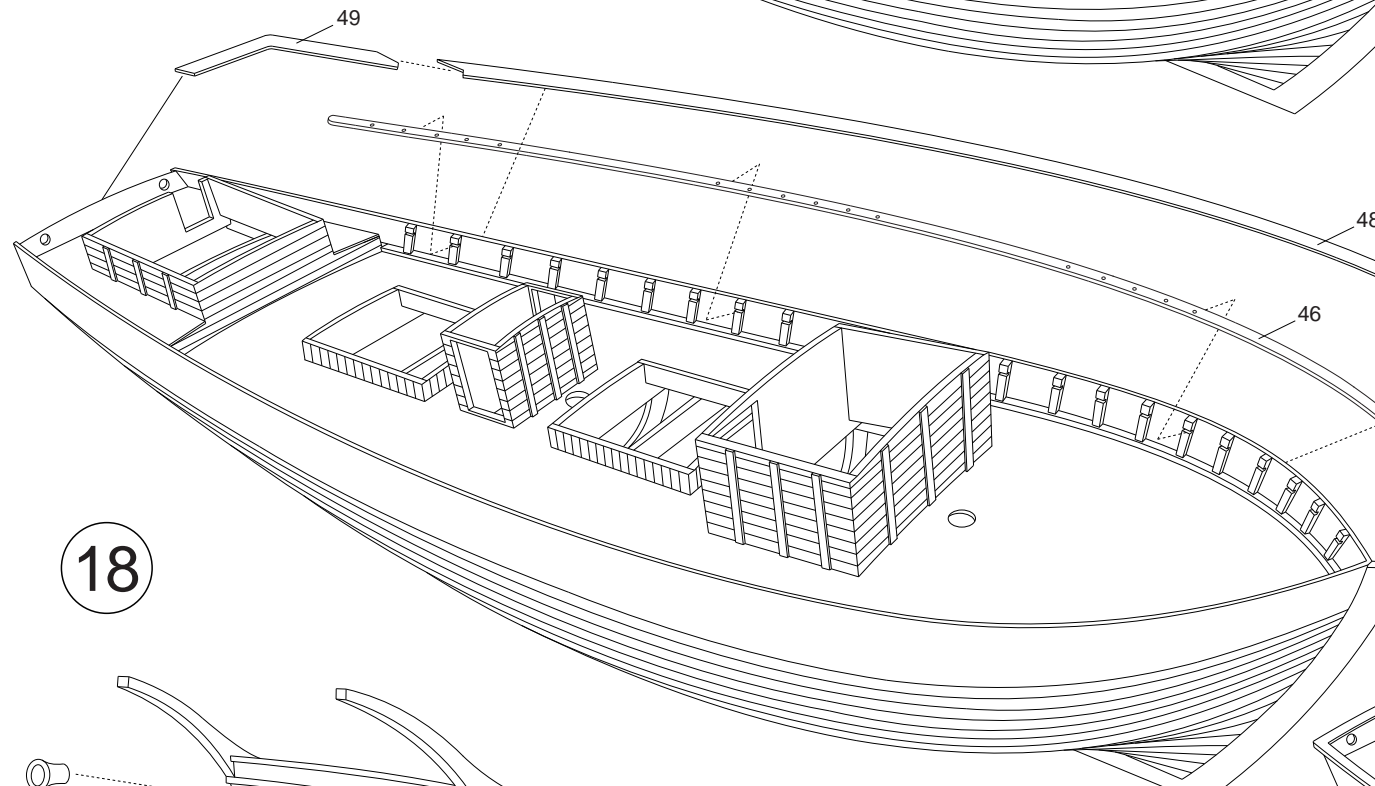

17

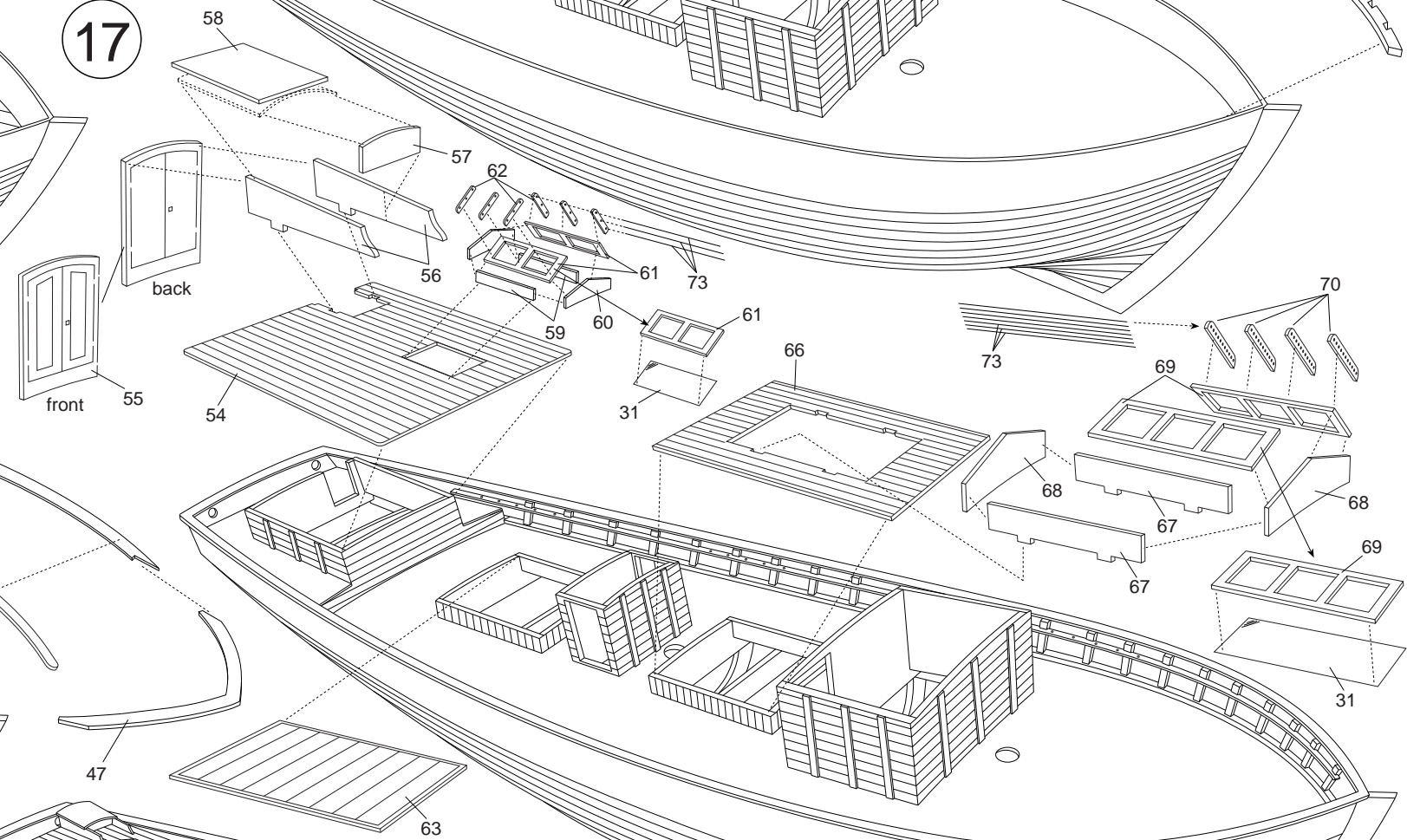

18

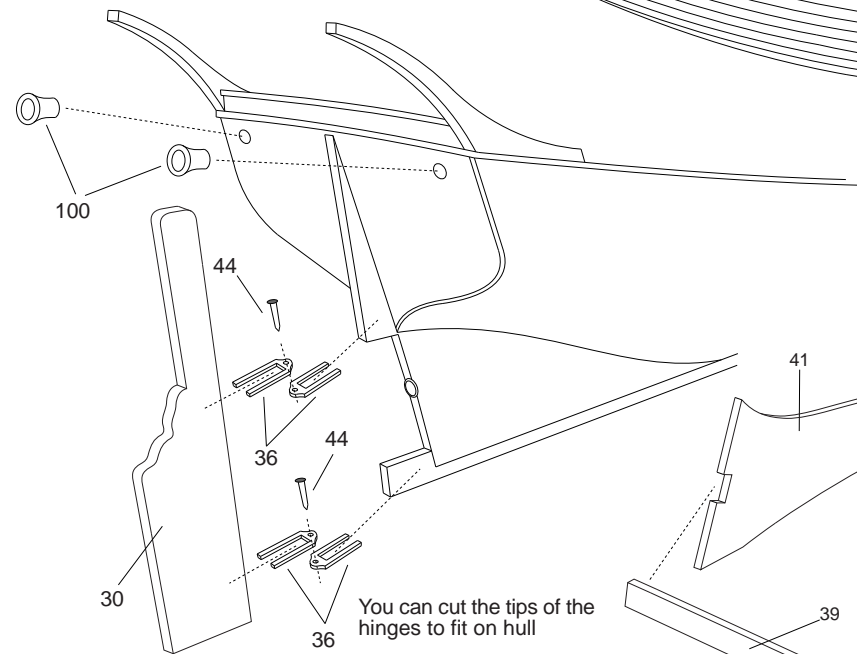

19

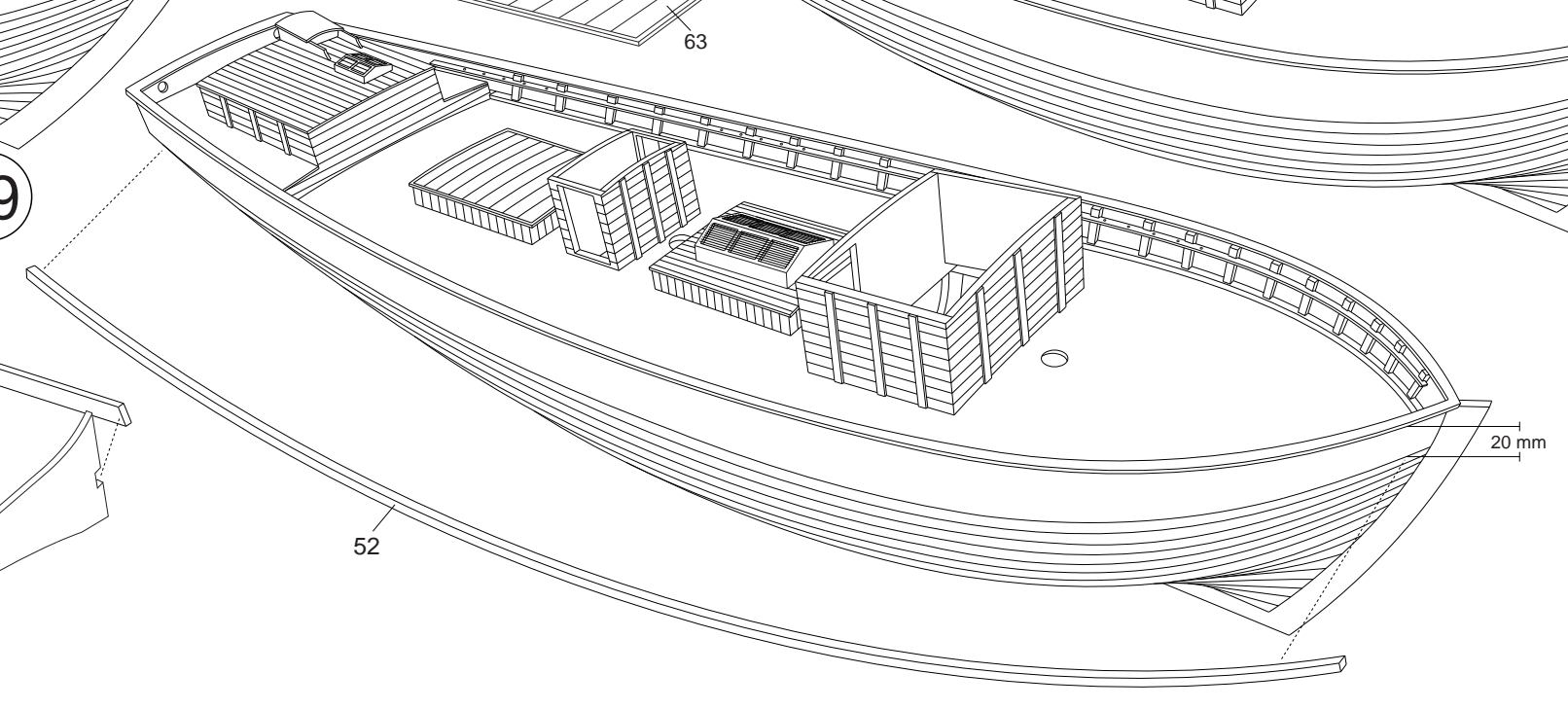

You can cut the tips of the hinges to fit on hull

20

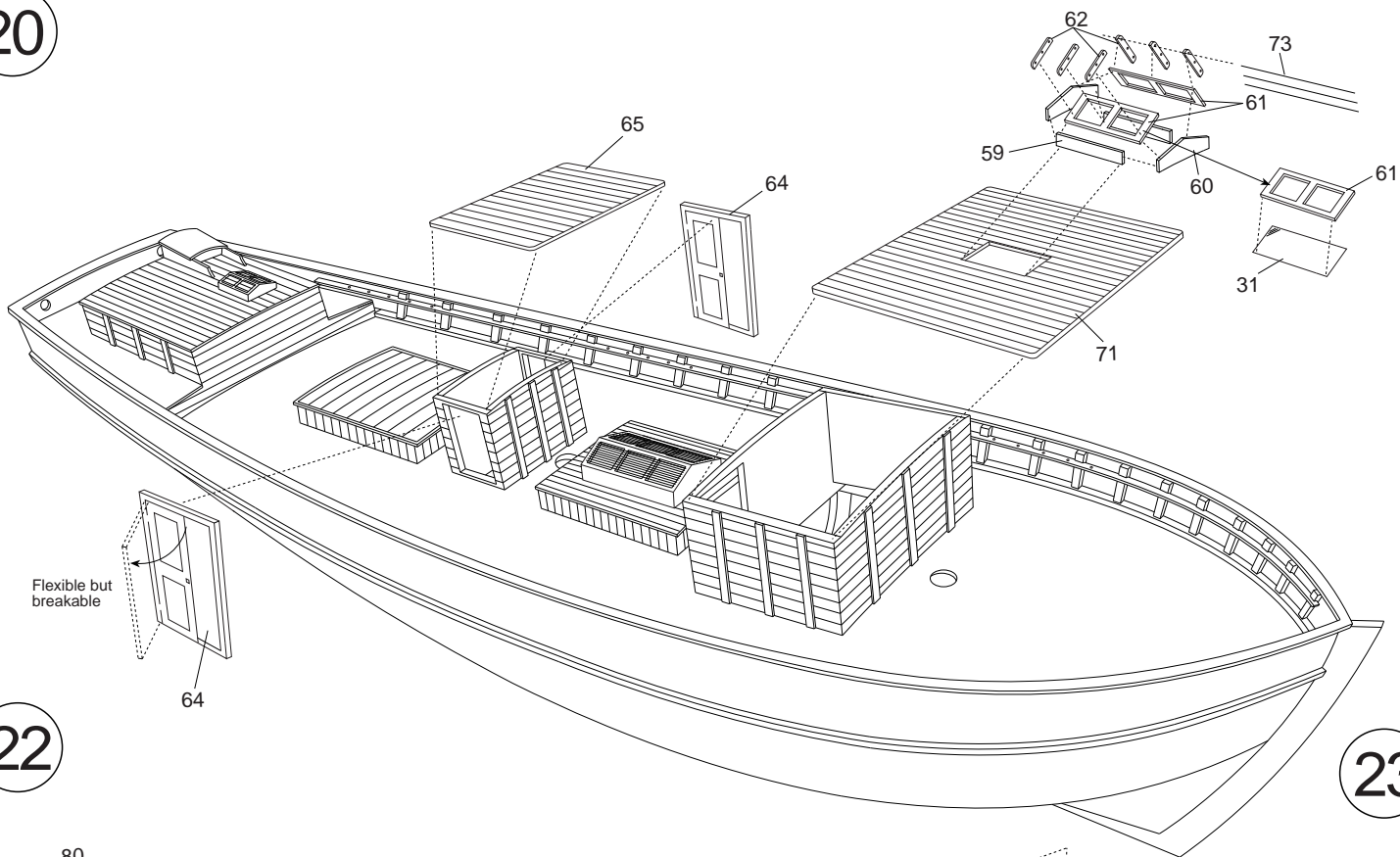

21

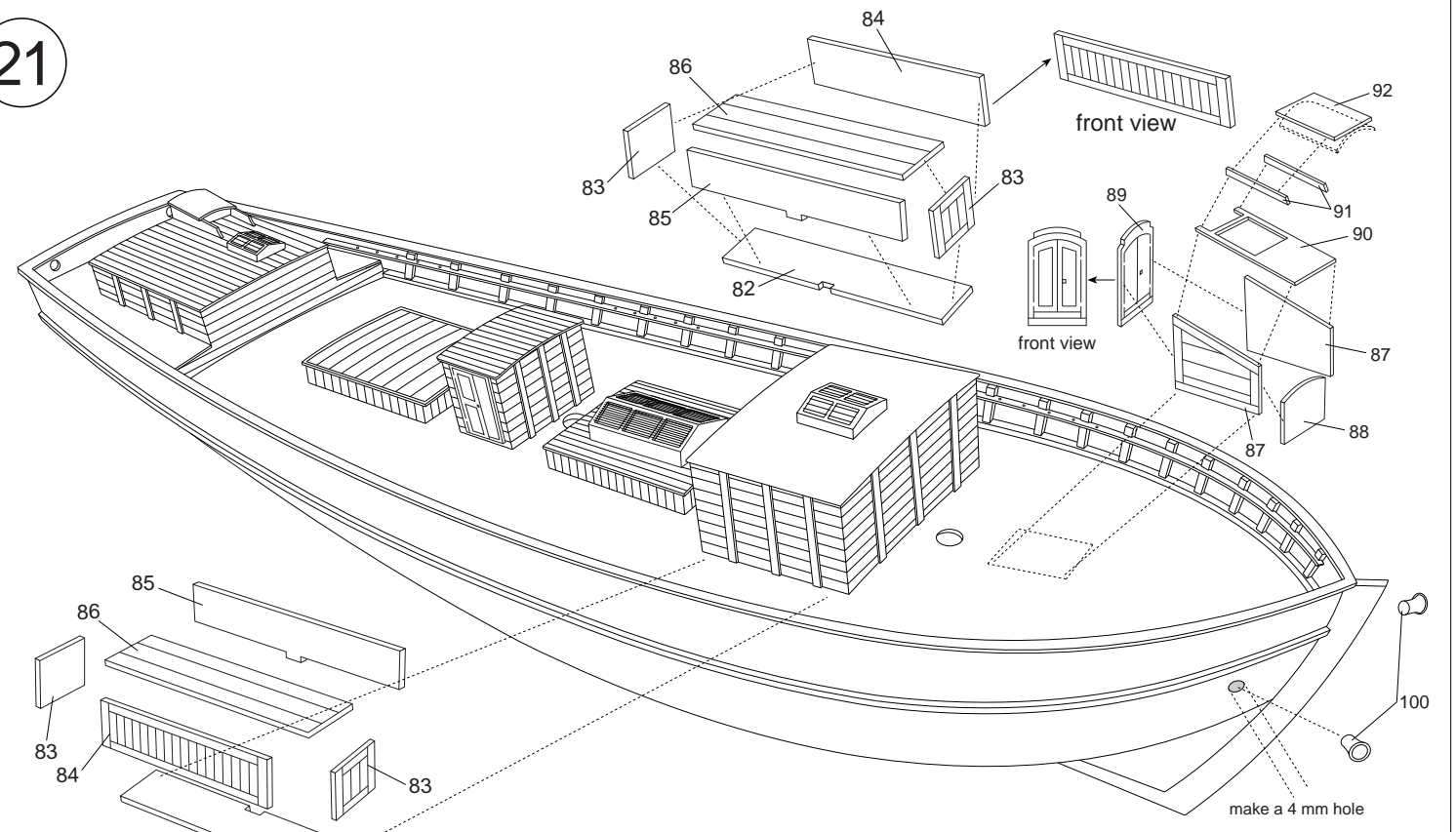

22

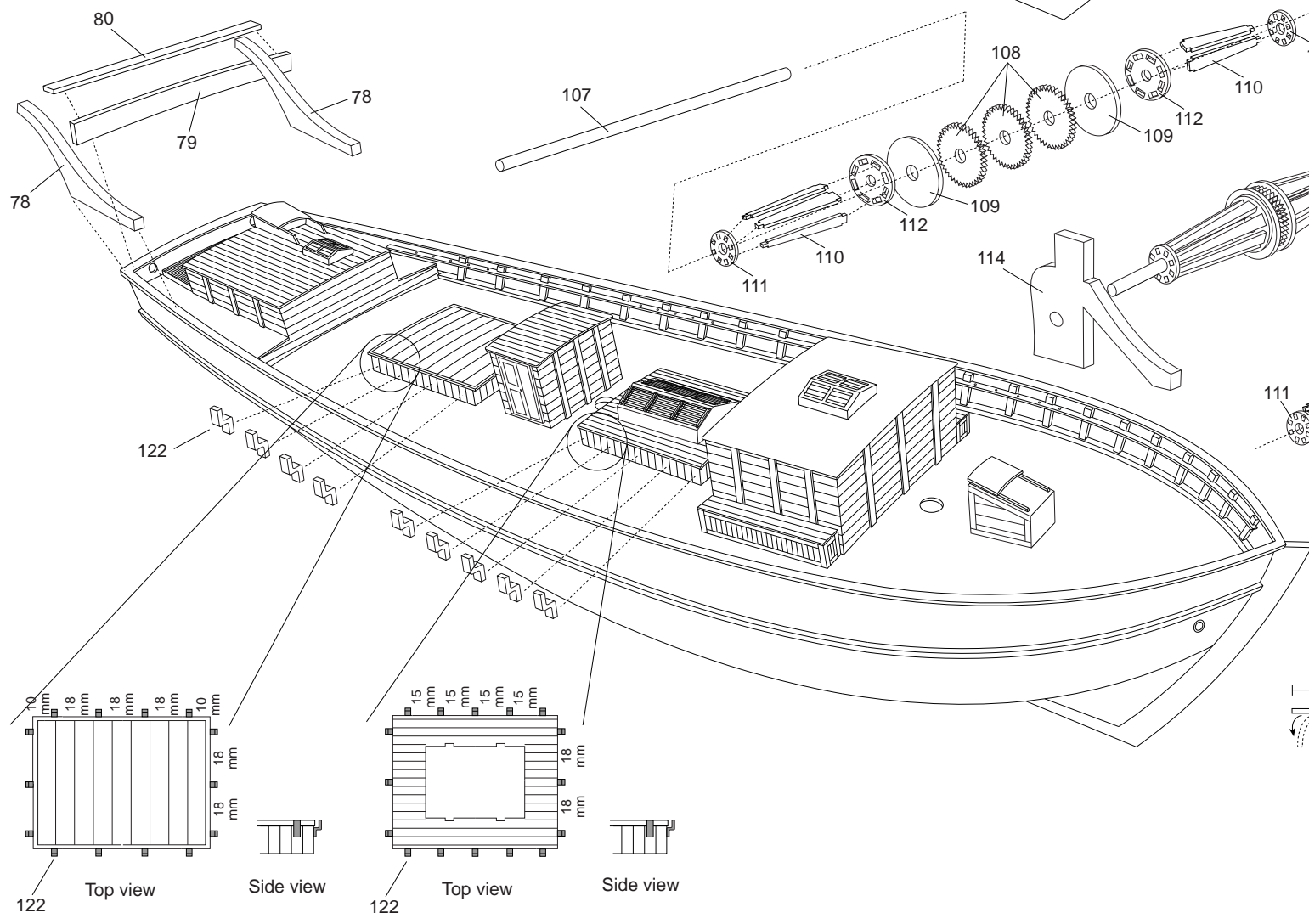

23

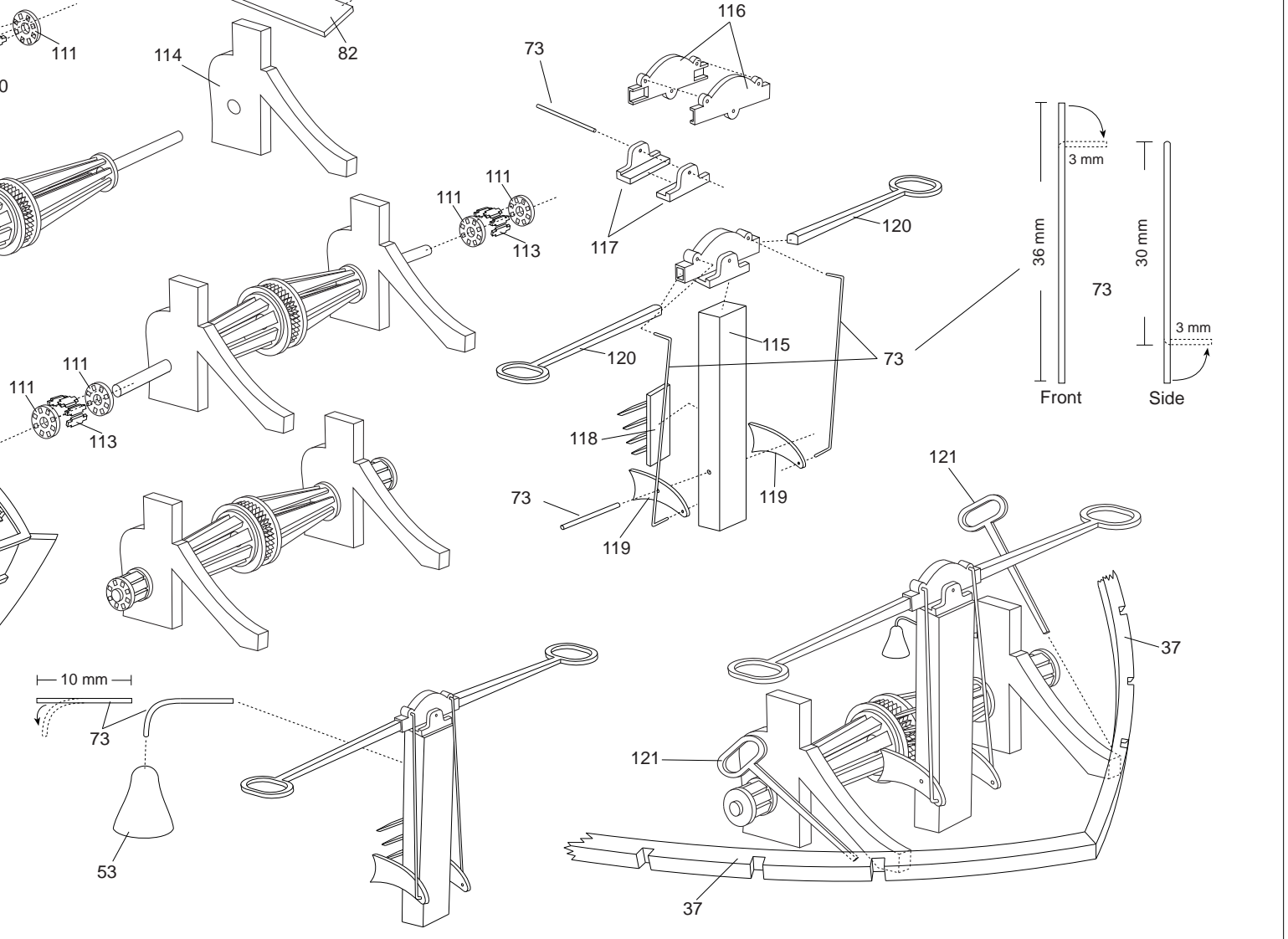

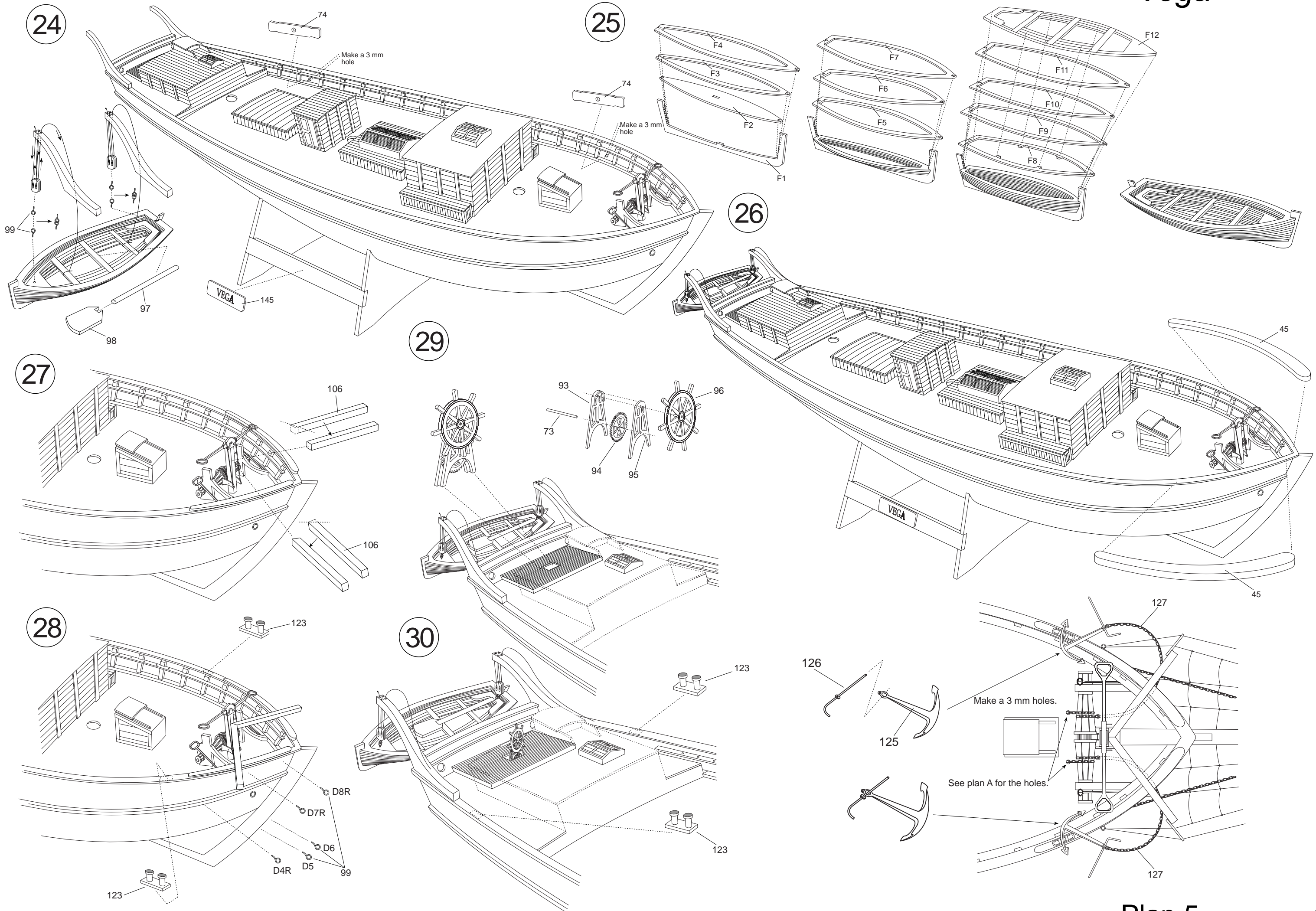

31

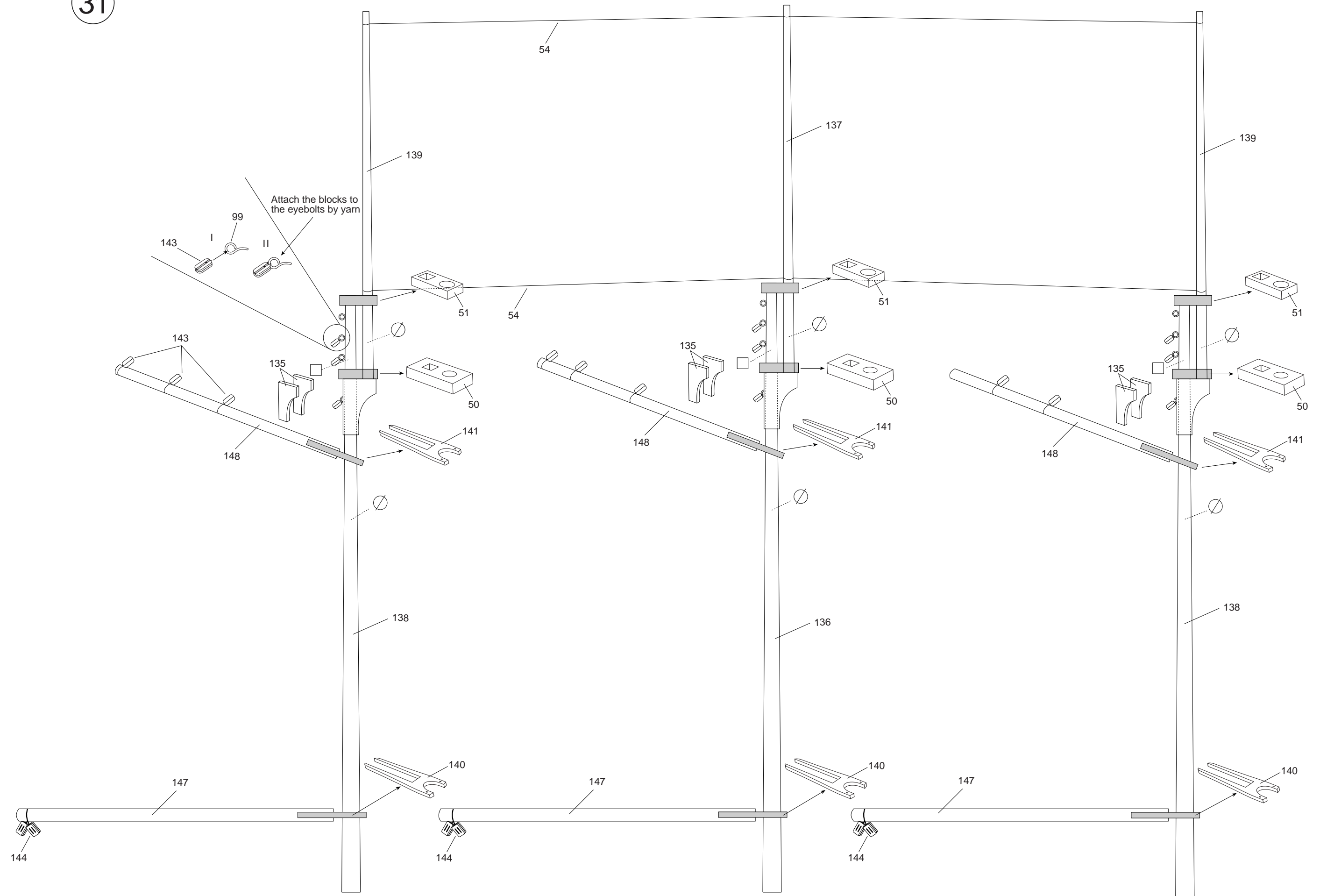

Plan 6

32

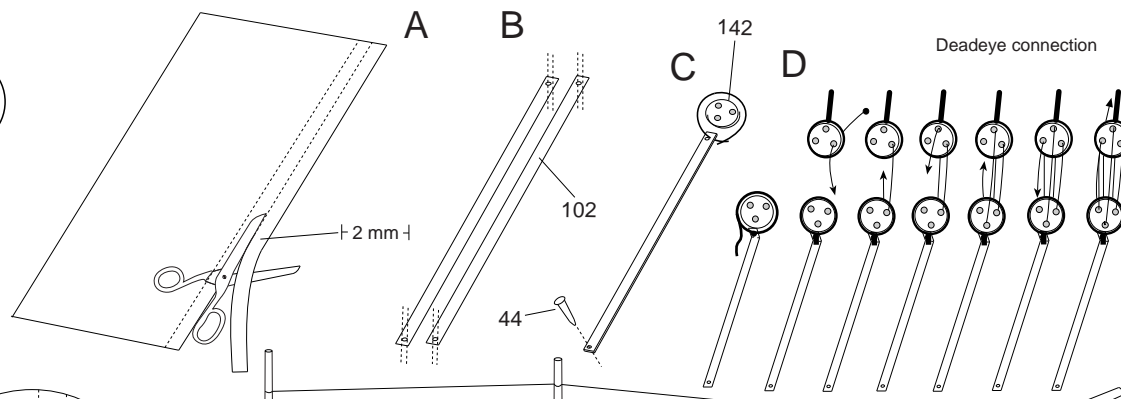

33

34

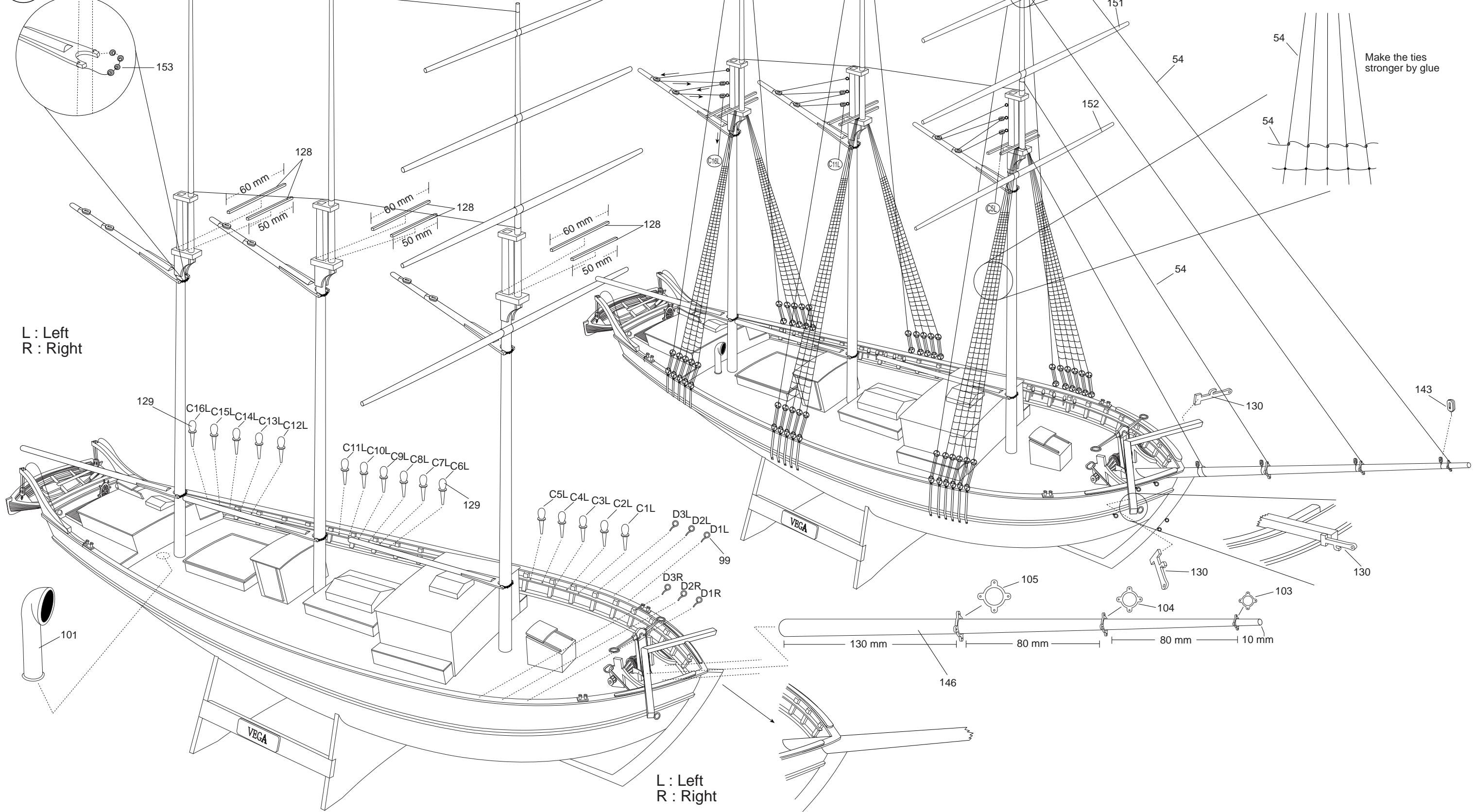

L : Left  
R : Right

L : Left  
R : Right

35

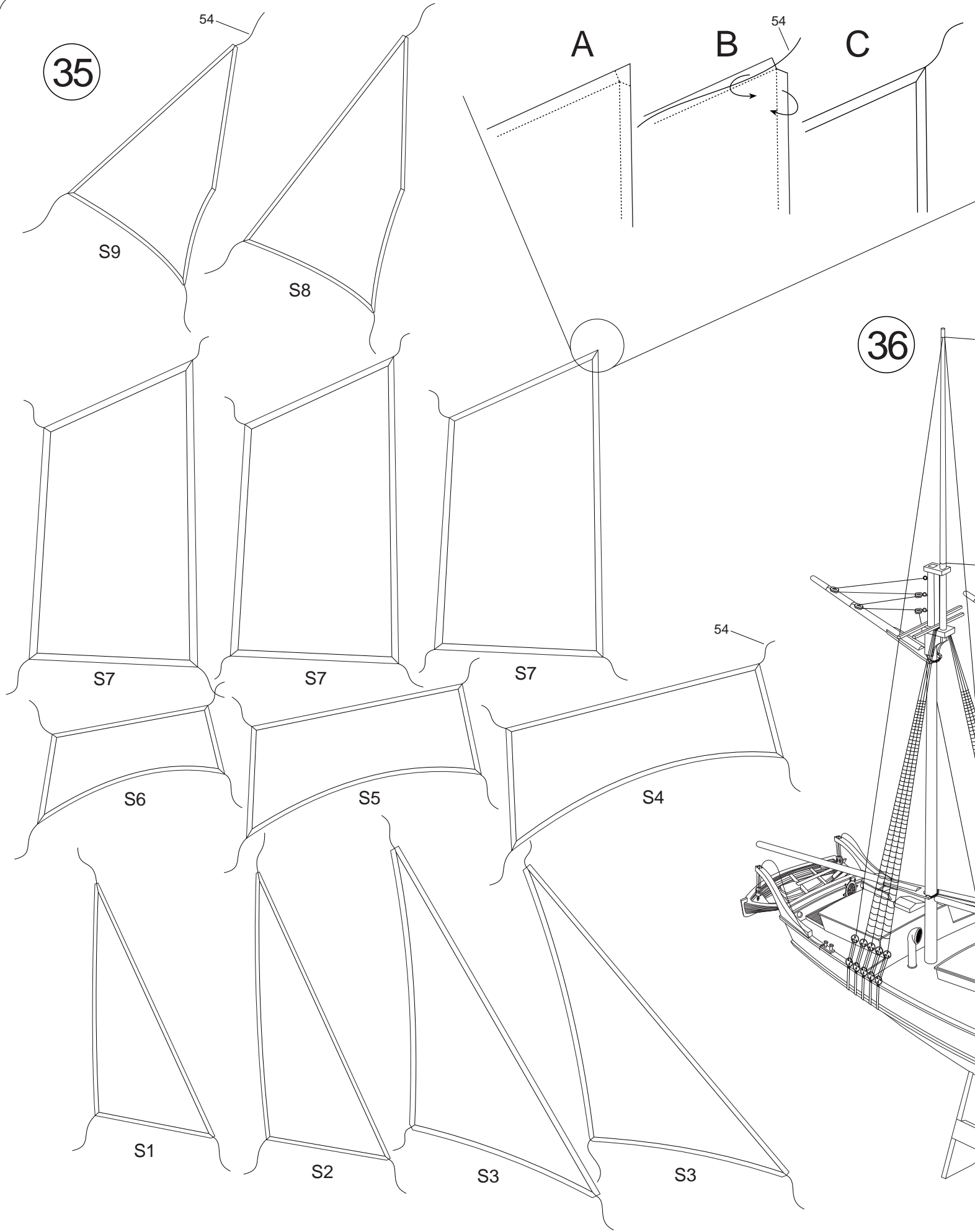

Fold and sew or glue the edges of the sails by passing the yarn through.

Do ironing the sails before attach to the model.

37

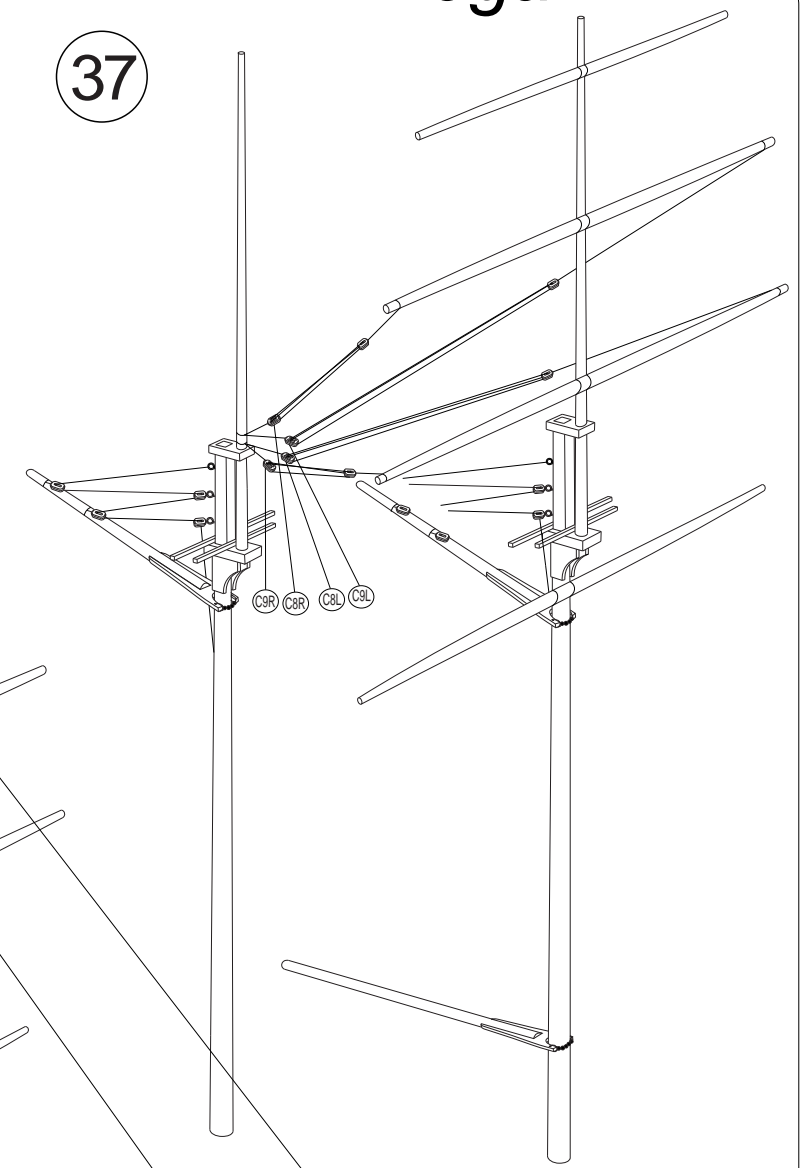

36

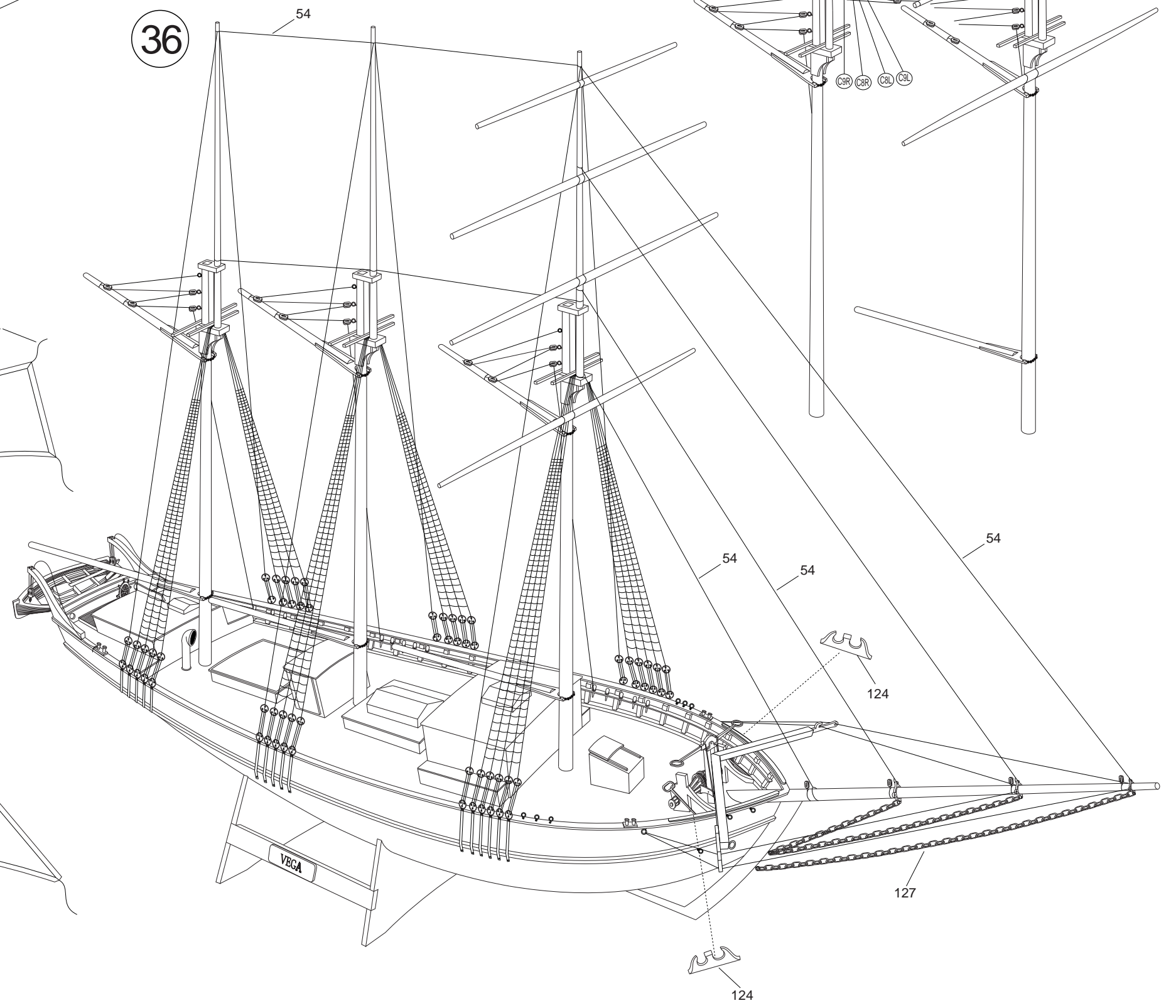

38

Detail of sail sewing.

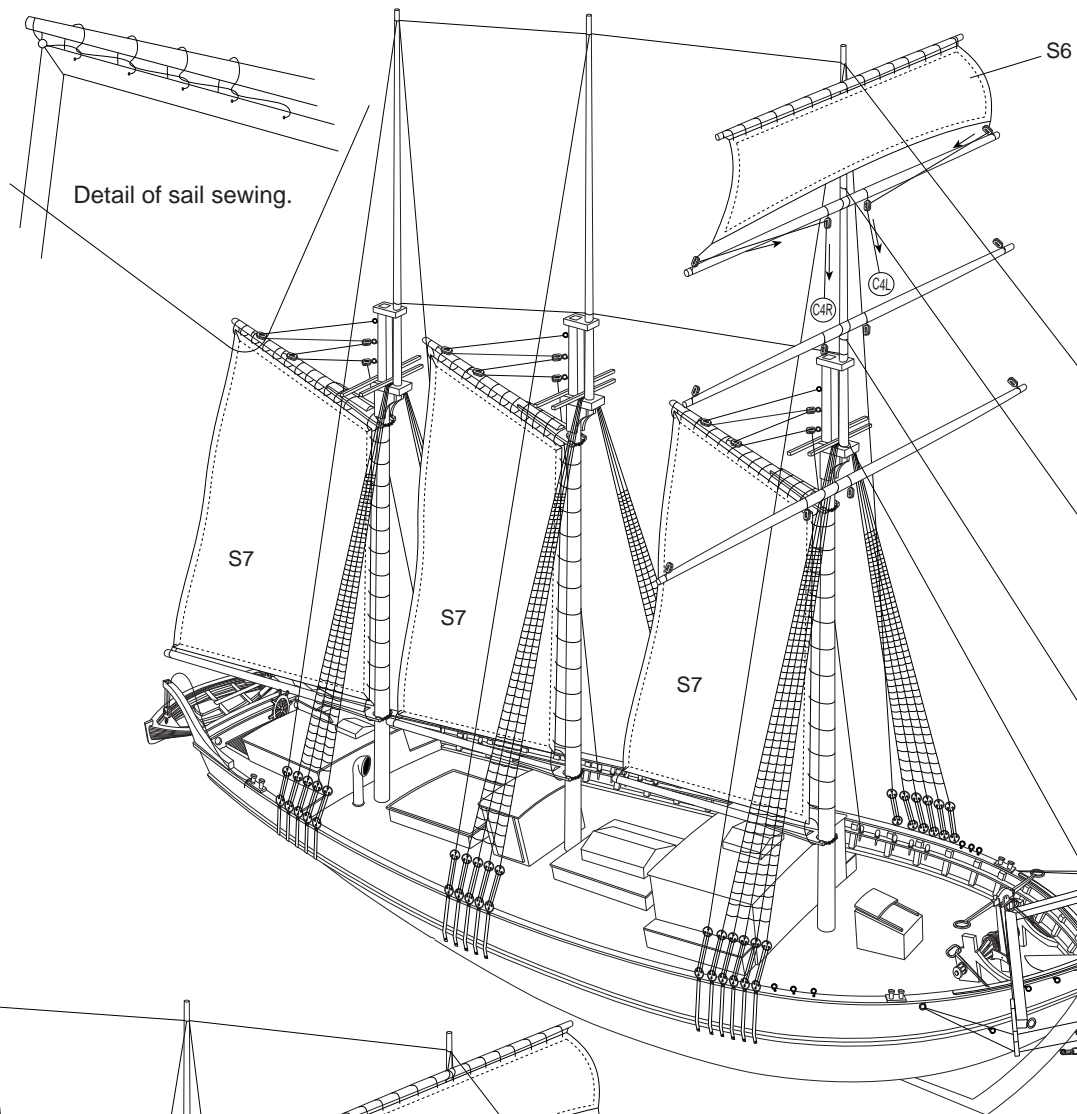

39

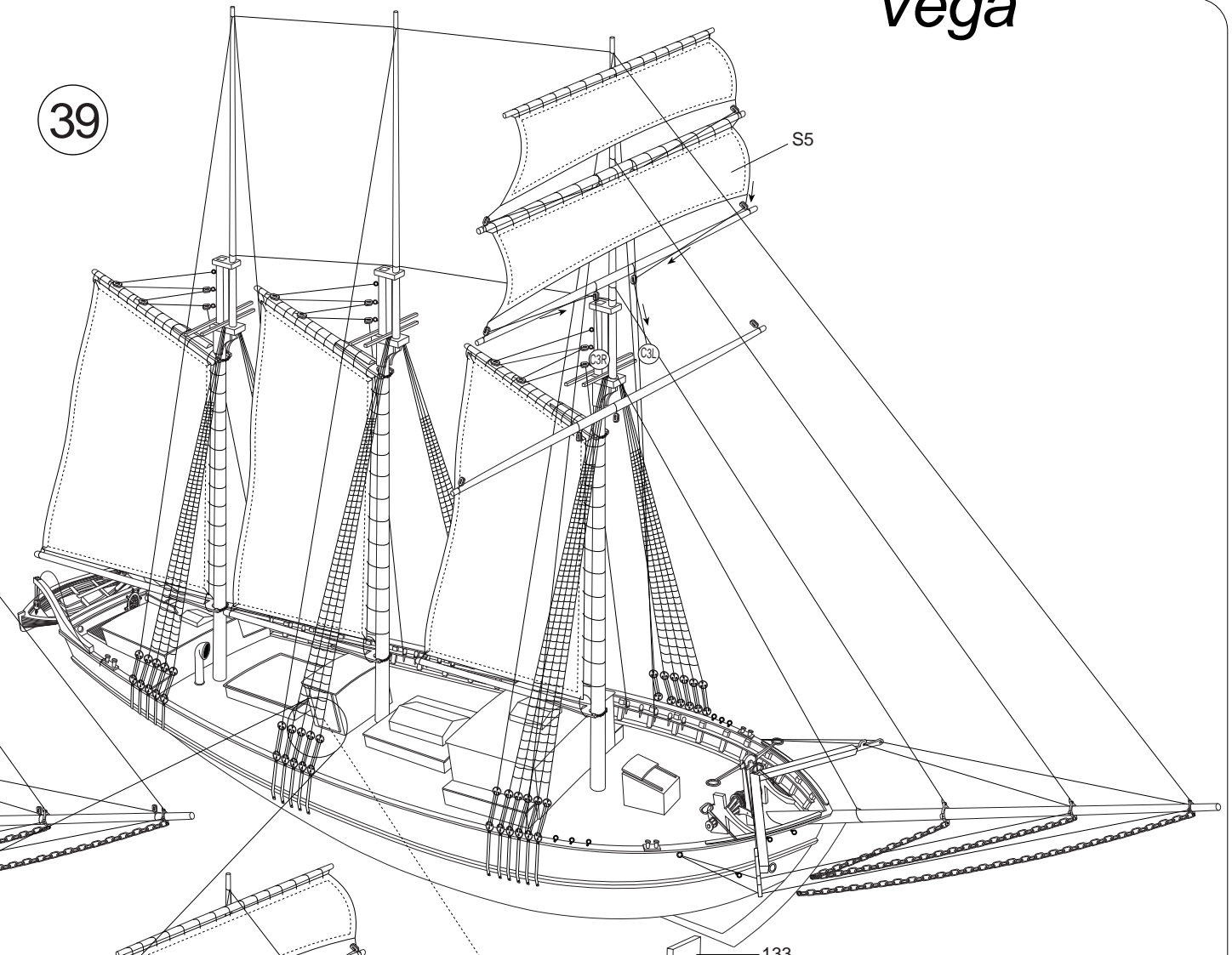

40

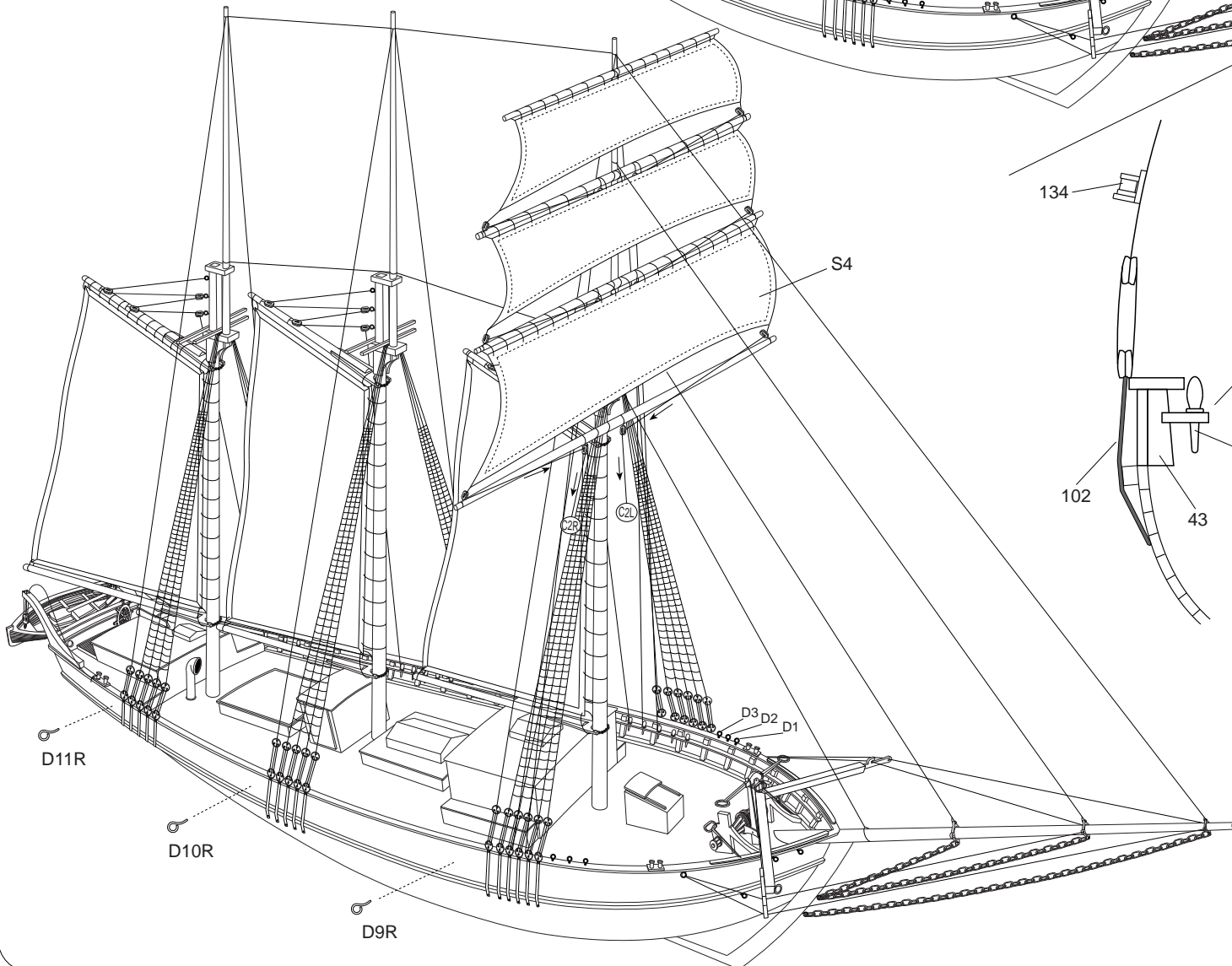

41

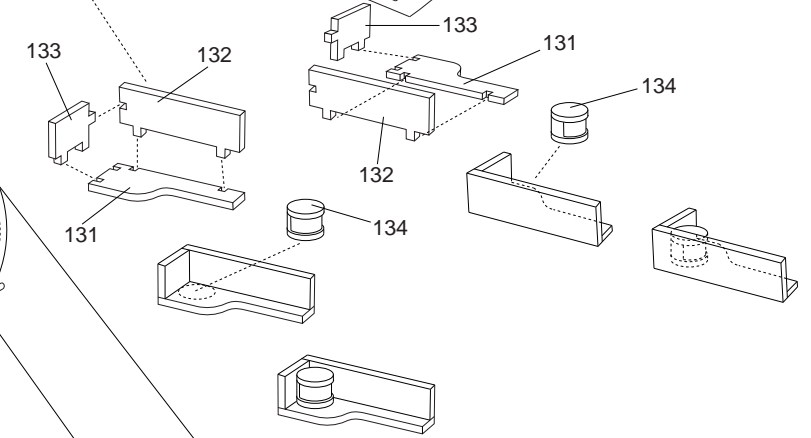
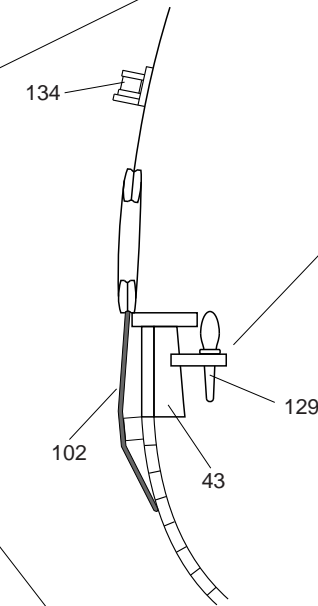

42

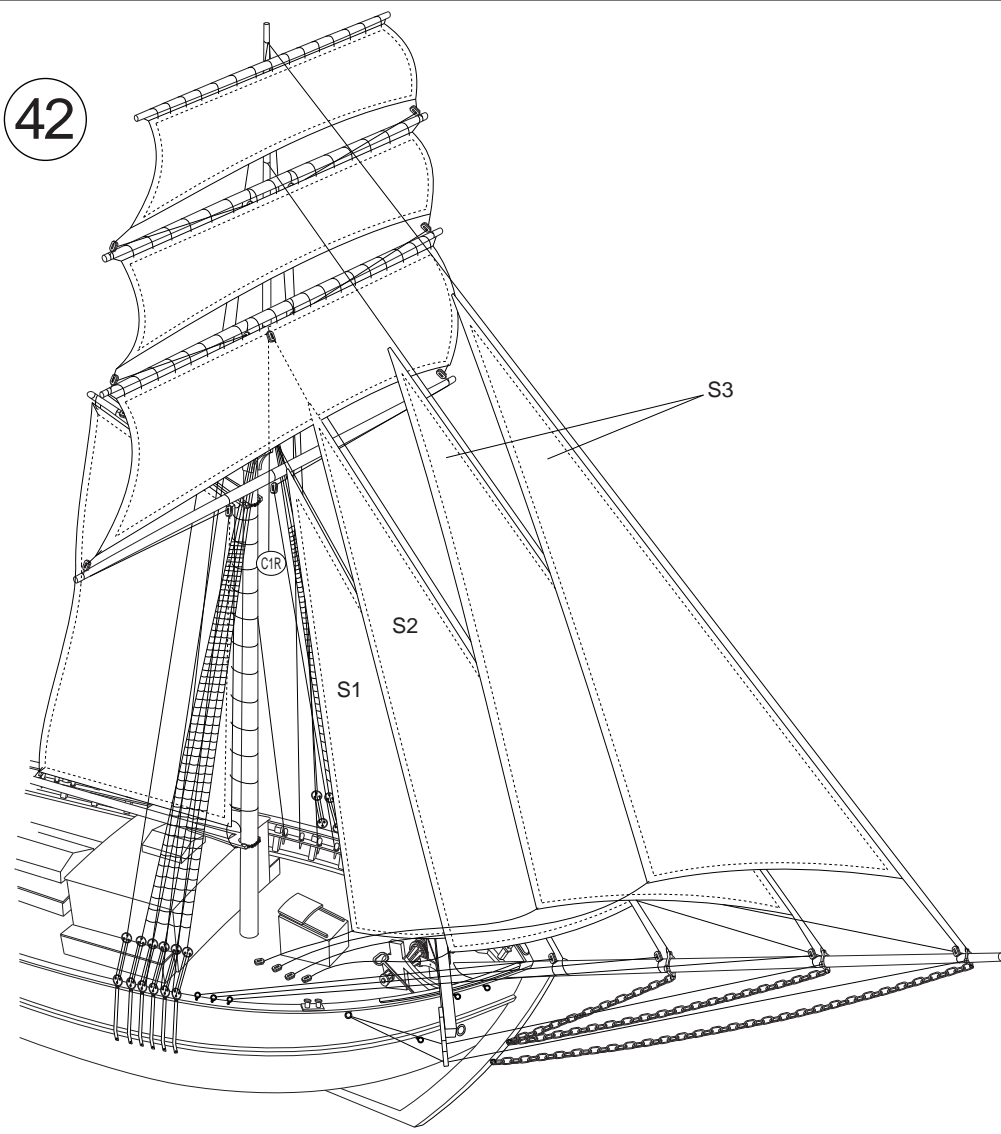

43

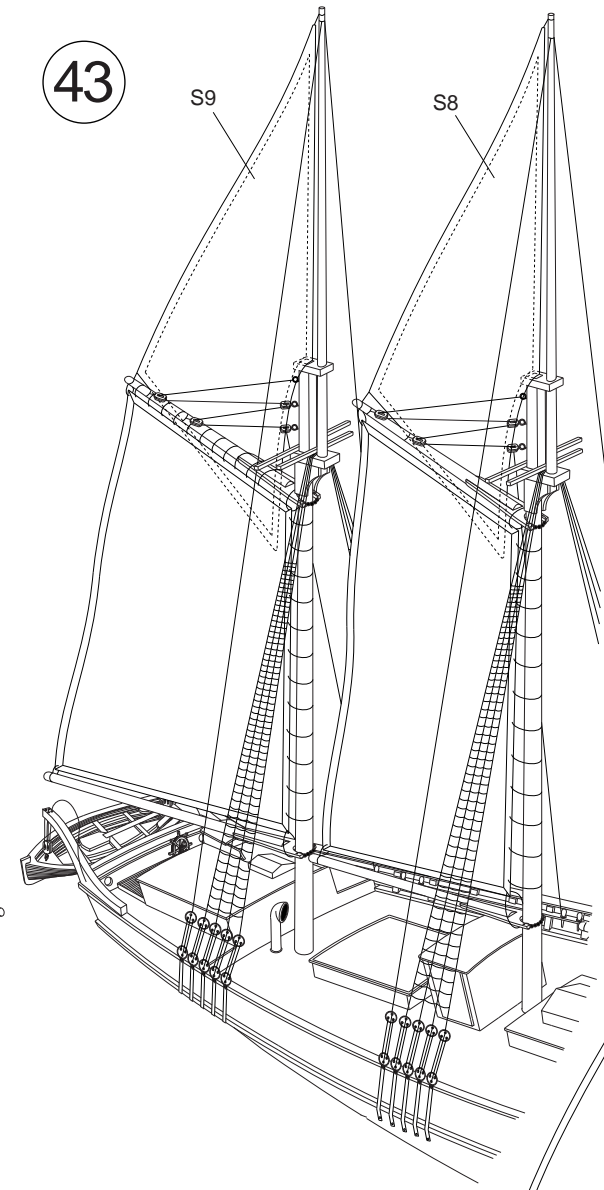

44

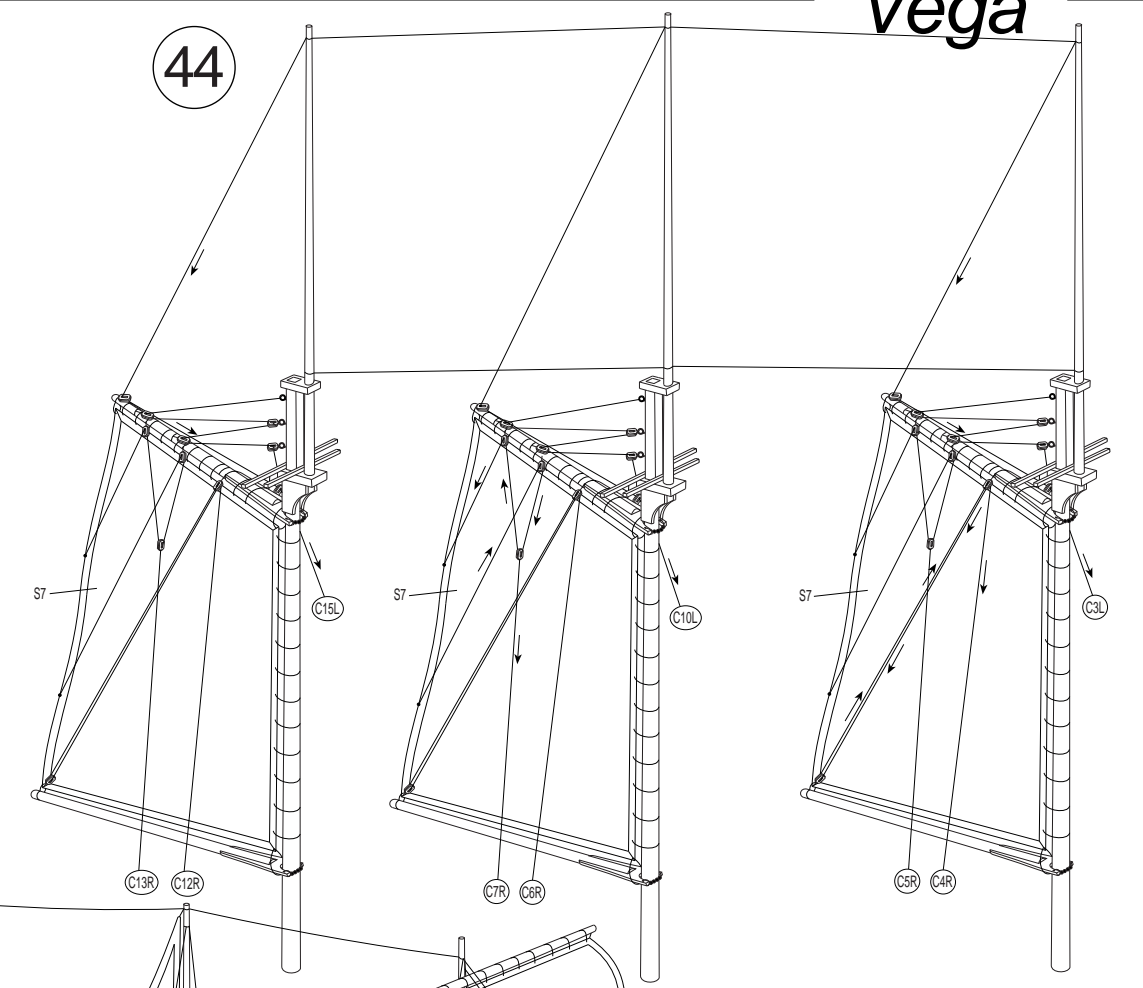

45

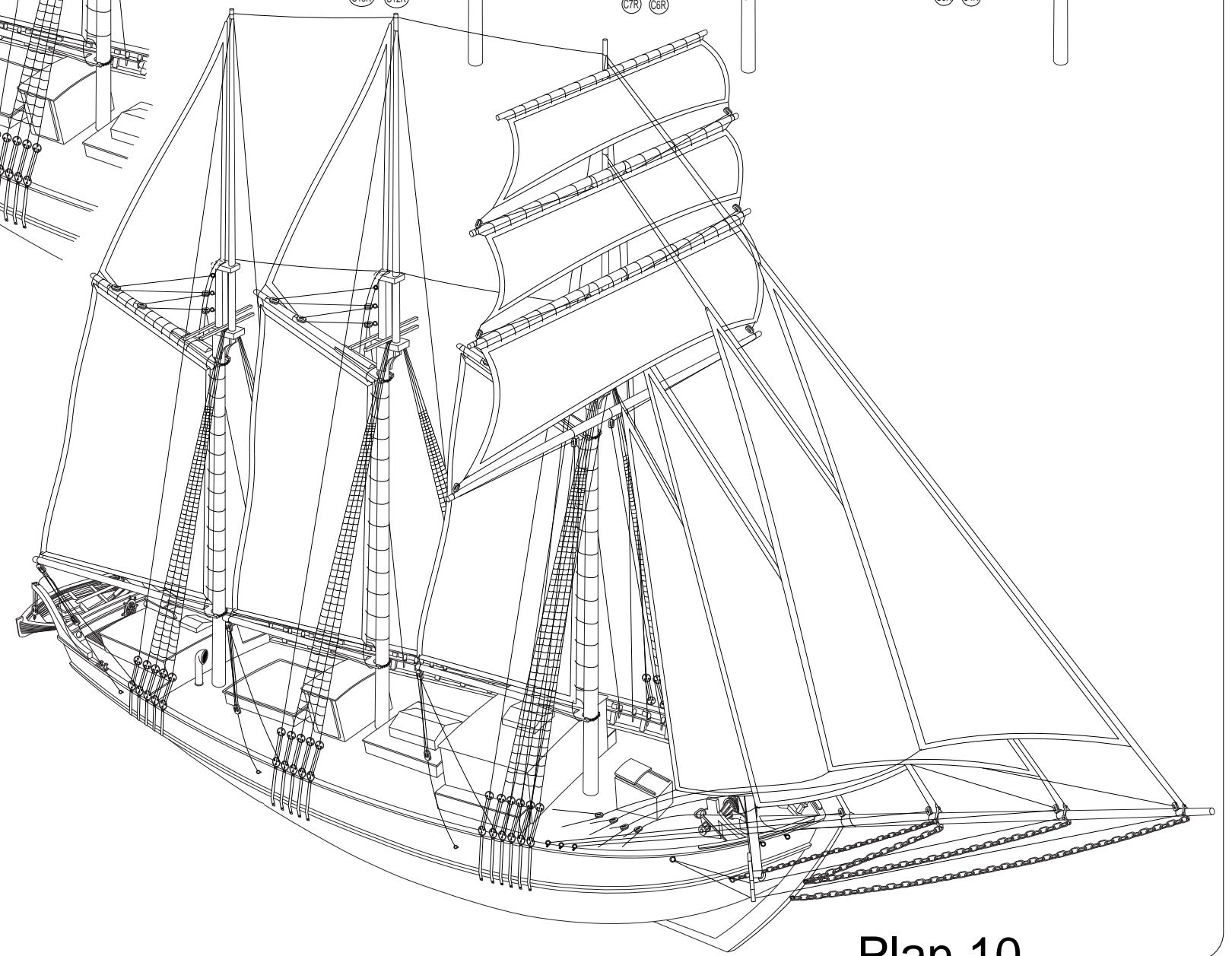
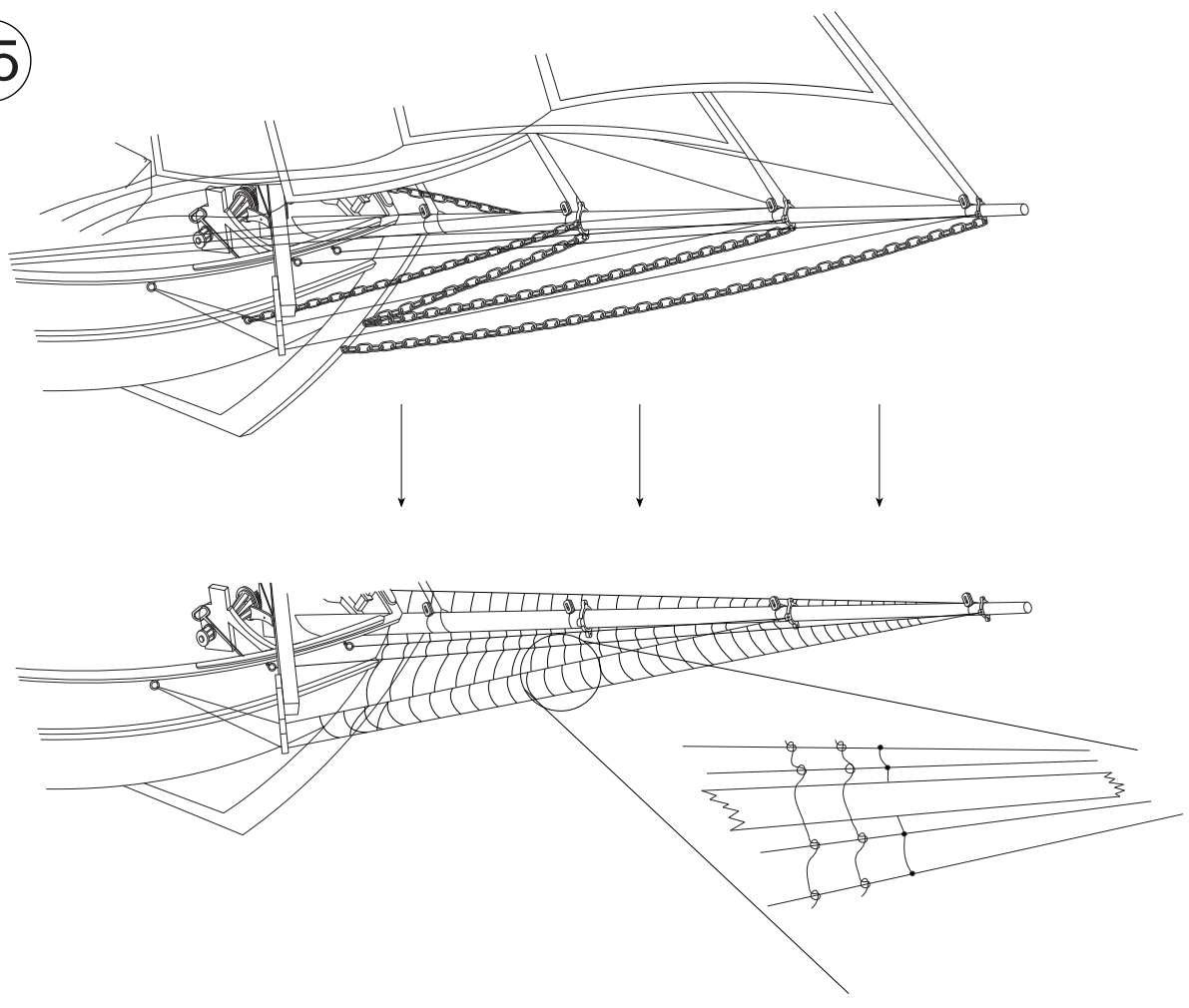



## ASISTANT GUIDE

- ❖ Please read the instructions carefully before you start to build your model. Take notes if needed. So, you may find out the materials and the tools those you need.
- ❖ Use model knife to take out the parts the plywood sheets. Do not take them out with hand!
- ❖ Change of temperature effects on plywoods quickly. So that, do not release the plywoods. Keep them on a flat surface by putting weight on them.
- ❖ You may stick together the wooden parts easily if you sand the brown areas caused by laser with sand paper.
- ❖ You should use super glue and white glue to stick together the wooden parts and use the super glue for metal parts.
- ❖ Building the keel of your model, before stick the frames, be sure the frames properly seated on the keel. Otherwise you can't build the body of the model rightly. Exactly be sure that left and right side of the frames are compatible and symmetrical.
- ❖ After building the keel of your model, before the covering, you should test the frame edges by a cover strip. You should sand with a piece of sandpaper the frame edges at the right degree to touch the strips on to the surface exactly. The curves are mostly the front and back side of the body.
- ❖ You should keep the strip tips in the bowl filled with water approximately one hour. So that you may curve the strips on the curves easily these are mostly at the end and the front of the hull.
- ❖ You should cover the strip starting from the top for each side symmetrically.
- ❖ You should cut the upper side of the strip when overlap occurs especially at the front curve of the body.
- ❖ To make equal the surface of the body that caused by planking, you should sand with a piece of sandpaper (Firstly you should use thick sandpaper, then you can apply thin sandpaper), . You should fill the gaps after this processing. You may use leftover strips for wide gaps and model putty for small gaps.
- ❖ If you don't want to appear wooden tissue of the body of your model body; first, apply filler undercoat then sand with a thin sandpaper to make it ready to apply putty. Apply putty whole body and sandpaper again. Apply one more coat filler undercoat and sandpaper. You should not use very thick sandpaper to sand the putty and filler undercoat. You should repeat this process until you get the results as you want. You should apply undercoat paint to find out if any mistake appears at the body. The body gets ready for painting after these applications. You may use model brushes for filler coating. In order to understand whether the materials (such paint, filler, undercoat, varnish, etc.) are compatible with each other, you should test on the unnecessary parts.
- ❖ Some of the model's logo, name or the number are produced from decal paper. You should keep them in a bowl filled with warm water for two or three minutes. You should apply them to their places while releasing from their paper. You may attach easily If you apply gloss varnish to the place before applying the decals. You may apply matt, gloss or satin varnish after this application preferably.
- ❖ You should keep your model away from direct sunlight, heat and moist to avoid deformation in the course of time.

# VEGA PART LIST

[www.turkmodel.net](http://www.turkmodel.net)

[www.facebook.com/turkmodel](http://www.facebook.com/turkmodel)

NO	ITEM	DESCRIPTION	SIZE	TYPE
1-2	2	Keel	4 mm	<i>Plywood</i>
3...15	13	Frames	4 mm	<i>Plywood</i>
16-17	4	Set square parts	4 mm	<i>Plywood</i>
18	3	Post houses	4 mm	<i>Plywood</i>
19-20-21	4	Front cabin parts	4 mm	<i>Plywood</i>
22-23	4	Front hold parts	4 mm	<i>Plywood</i>
24-25	4	Middle cabin parts	4 mm	<i>Plywood</i>
26-27	4	Back hold parts	4 mm	<i>Plywood</i>
28-29	3	Back cabin parts	4 mm	<i>Plywood</i>
30	1	Rudder	4 mm	<i>Plywood</i>
31	-	Glass	-	<i>Clear sheet</i>
32	62	Cover strips	1,65x5x720 mm	<i>Basswood</i>
33	1	Main deck	1,7 mm	<i>Plywood</i>
34	1	Back deck	1,7 mm	<i>Plywood</i>
35	85	Deck and cabin cover strips	0,5x4x380 mm	<i>Ayous</i>
36	4	Rudder hinges	-	<i>White metal</i>
37-38	4	Rail vertical laths houses	4 mm	<i>Plywood</i>
39-40-41	4	Base parts	4 mm	<i>Plywood</i>
42	10	Rail vertical laths-long	4 mm	<i>Plywood</i>
43	38	Rail vertical laths-short	4 mm	<i>Plywood</i>
44	34	Nails	-	<i>Nails</i>
45	2	Support parts of top rails	4 mm	<i>Plywood</i>
46	2	Houses of belaying pins	1,7 mm	<i>Plywood</i>
47-48-49	5	Rail parts	1,7 mm	<i>Plywood</i>
50	3	Post connectors-large	4 mm	<i>Plywood</i>
51	3	Post connectors-small	4 mm	<i>Plywood</i>
52	2	Laths	2x2,5x740 mm	<i>Basswood</i>
53	1	Bell	-	<i>White metal</i>
54	1	Rope	-	<i>Yarn</i>
55...58	5	Entrance parts of back cabin	1,7 mm	<i>Plywood</i>
59...62	24	Top windows of the cabins	1,7 mm	<i>Plywood</i>
63	1	Back hold lid	1,7 mm	<i>Plywood</i>
64	2	Middle cabin doors- left and right	1,7 mm	<i>Plywood</i>
65	1	Roof part of the middle cabin	1,7 mm	<i>Plywood</i>
66	1	Top part of the front hold	1,7 mm	<i>Plywood</i>
67...70	14	Windows parts of the front hold	1,7 mm	<i>Plywood</i>
71	1	Roof of the front cabin	1,7 mm	<i>Plywood</i>
72	1	Door of the front cabin	1,7 mm	<i>Plywood</i>
73	1	Wire	0,5x1000 mm	<i>Wire</i>
74	4	Rail support parts of rope tie	1,7 mm	<i>Plywood</i>
75-76-77	4	Rudder deck parts	1,7 mm	<i>Plywood</i>
78	2	Hanger of lifeboats	Ready	<i>Wooden</i>
79-80	2	Back rail parts	1,7 mm	<i>Plywood</i>
82...86	12	Chest parts of the front cabin	1,7 mm	<i>Plywood</i>
87...92	8	Winch cabinet parts	1,7 mm	<i>Plywood</i>
93-94-95	3	Stand parts of the rudder wheel	-	<i>White metal</i>
96	1	Rudder wheel	-	<i>White metal</i>
97	2	Row handle	Ready	<i>Wooden</i>
98	2	Row	Ready	<i>Wooden</i>
99	50	Eyebolt	Ready	<i>Metal</i>
100	4	Porthole	Ready	<i>Metal</i>
101	1	Air entrance pipe	-	<i>White metal</i>
102	2	Sheet for the chain plates	6x6 cm	<i>Aluminium sheet</i>
103	1	4-hole ring-small	-	<i>White metal</i>

## VEGA PART LIST

Page 2

NO	ITEM	DESCRIPTION	SIZE	PART TYPE
104	1	4-hole ring-medium	-	White metal
105	1	4-hole ring-large	-	White metal
106	2	Anchor hangers	4x4x57 mm	Basswood
107	1	Winch shaft	3x70 mm	Wire
108	3	Winch gears	Ready	Plexy-glass
109	2	Winch parts	Ready	Plexy-glass
110...113	38	Winch parts-2 sets	1,7 mm	Plywood
114	2	Winch stands	Ready	Wooden
115	1	Stand of the winch handles	6x10x28 mm	Basswood
116...121	11	Winch parts	-	White metal
122	30	Hangers of the holds	Ready	Plexy-glass
123	4	Double-head bollards	-	White metal
124	2	Triple-head bollards	-	White metal
125	2	Anchor	-	White metal
126	2	Anchor bars	-	White metal
127	-	Chain	120 cm	Metal
128	1	Post laths	2x2x400 mm	Mahogany
129	36	Belaying pins	Ready	Walnut
130	2	Rope connector part of the bowsprit	-	White metal
131-132-133	6	Board light house parts-2 sets	-	White metal
134	2	Board lights	-	White metal
135	6	Support parts of the post connectors	1,7 mm	Plywood
136	1	Main post-bottom	6x9x450 mm	Dowel conic
137	1	Main post-top	3,5x6x260 mm	Dowel conic
138	2	Front and back posts-bottom	6x9x425 mm	Dowel conic
139	2	Front and back posts-top	3,5x6x250 mm	Dowel conic
140	3	Boom forks-large	Ready	Wooden
141	3	Boom forks-small	Ready	Wooden
142	68	Deadeyes	Ready	Walnut
143	75	Single-hole blocks	Ready	Walnut
144	25	Double-hole blocks	Ready	Walnut
145	2	Nametag	1,7 mm	Plywood
146	1	Bowsprit	5x9x300	Dowel conic
147	3	Boom-bottom	7x165 mm	Dowel
148	3	Boom-top	5x150 mm	Dowel
149	1	Horizontal front post boom	5x210 mm	Dowel
150	1	Horizontal front post boom	5x275 mm	Dowel
151	1	Horizontal front post boom	6x300 mm	Dowel
152	1	Horizontal front post boom	7x350 mm	Dowel
153	60	Beads	Ready	Plastic
S1...S9	12	Sails	Ready	Fabrig
F1	1	Lifeboat keel	1,7 mm	Plywood
F2...F12	12	Lifeboat parts	1,7 mm	Plywood

# YARDIMCI KILAVUZ



- ❖ Maketinizin yapımına başlamadan önce planı ve plandaki yazıları dikkatlice gözden geçiriniz. Gerekli gördüğünüz yerlere notlar alınız. İhtiyacınız olan yardımcı malzeme ve aletleri de bu şekilde tespit edebilirsiniz.
- ❖ Kontraplak üzerindeki parçaları çıkartmak için mutlaka maket bıçağı kullanınız, el ile kopartmayınız!
- ❖ Kontraplaklar hava ısı ve neme karşı çok çabuk reaksiyon gösterirler. Bu yüzden modelin yapımı sırasında kontraplak parçaları serbest durumda bırakmayınız. Üzerine ağırlık koyarak düz bir satih üzerinde muhafaza ediniz.
- ❖ Maketin üretiminde kullanılan lazer kesimden kaynaklanan, ahşap üzerindeki kahverengi kısımları zımpara ile temizlerseniz daha iyi yapışmasını sağlarsınız.
- ❖ Ahşap parçaları yapıştırmak için beyaz ağaç tutkalı ve hızlı yapıştırıcı, metal parçalar için de hızlı yapıştırıcı kullanabilirsiniz.
- ❖ Maketin iskeletini oluştururken postaların omurga üzerine tam ve doğru bir biçimde oturduğundan emin olmadan yapıştırmayınız. Aksi halde gövdeyi düzgün bir şekilde oluşturamazsınız. Postaların birbirleri ile uyumlu bir şekilde sağ ve sol taraflarının simetrik olarak oturduğundan kesinlikle emin olunuz.
- ❖ Omurga iskeletini oluşturduktan sonra, çıta sarma işlemine geçmeden önce, posta kenarlarını bir sarma çitası ile prova edip, sarma çitasının özellikle maketin kavis alan ön ve arka kısımlarına doğru posta kenarlarının yüzeyine tam olarak temas etmesini sağlamak için uygun açıda zımparalayınız.
- ❖ Maketin gövde kısmını oluşturmak için çitaları postalar üzerine sarma işlemine başlamadan önce çitaları su dolu bir kapta bir saat kadar tutunuz. Böylelikle sarma işlemi yaparken uç kısımlara doğru artan kavisleri rahatlıkla dönebilirsiniz.
- ❖ Sarma çitalarını her defasında sağ ve sol taraftan birer kez simetrik olarak üstten başlayarak sarınız. Sarma çitaları özellikle ön kısımda birbirlerinin üzerine binmeye başladıklarında üst kısımlarından tıraşlayarak inceltiniz.
- ❖ Sarma işlemi bittikten sonra öncelikle kalın ve ince zımpara ile yüzeyini çitalardan kaynaklı taşmaları düzeltmek için zımparalayınız. Bu işlemden sonra, gövdede oluşan boşluklar var ise; büyük boşlukları atık çitalara şekil vererek, daha küçük boşlukları da dolgu malzemeleri ile kapatınız.
- ❖ Maketin gövdesinde ahşap doku izleri görünmemesi gerekiyorsa; önce dolgu astarı ardından ince bir zımpara ile zımparalayıp gövdenin tamamını macun çekmeye hazır hale getiriniz ve gövdeye macun çekip tekrar zımparalayınız. Üzerine bir kat daha dolgu astarı atarak tekrar zımparalayınız. Dolgu astarı ve macunu zımparalarken çok kalın zımpara kullanmayınız. Gövde istediğiniz gibi olana kadar bu işlemleri tekrarlayınız. Kusur olup olmadığını anlamak için en son olarak astar boya atınız. Ondandır gövde boyanmaya hazır hale gelmiştir. Dolgu astarını fırça ile atabilirsiniz. Kullanacağınız kimyasal içeren maddelerin ( boya, vernik, dolgu macunu, astar boya, vs. gibi ) birbiri ile uyuşup uyuşmadığını anlamak için ayrı bir yerde deneme yapınız.
- ❖ Modellerin üzerindeki logo, isim ya da numaraların bazıları suda çözünen çıkartmalardan üretilmektedir. Bunları çok küçük bir kabın içindeki ılık suda iki-üç dakika bekleterek kağıtlarından ayrılmasını sağlayıp dikkatli bir biçimde uygulanacağı bölgeye yerleştirebilirsiniz. Uygulanacak bölge temiz olmalı. Uygulamadan önce bölgeye parlak vernik atarsanız çıkartmanın çok daha iyi tutmasını sağlarsınız. Daha sonra tekrar üzerine tercihinize göre mat, parlak ya da saten vernik atabilirsiniz.
- ❖ Bitmiş modelinizi zamanla deforme olmaması için güneş ışığı, sıcaklık ve rutubet gibi etkenlerden uzak bir yerde sergileyiniz.